

ASR012 Smart I²C TMR Angle Sensor

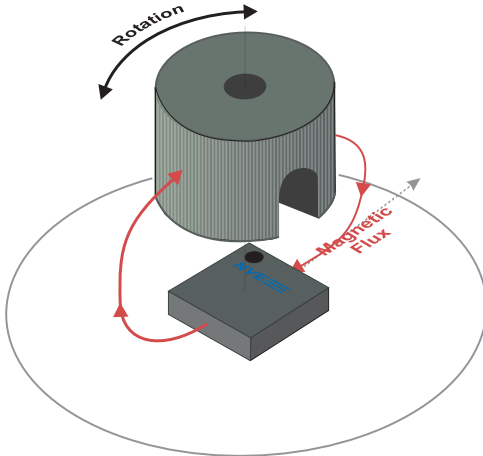

Features

- Rotational speeds to 375,000 RPM
- 3.3 volt or 5 volt compatible I²C interface
- PWM output
- Robust airgap and misalignment tolerances
- Factory calibrated
- Ultraminiature 2.5 x 2.5 x 0.8 mm TDFN6 package

Key Specifications

- 0.1° resolution
- ±0.2° repeatability
- Robust 6 to 20 mT field operating range
- Fast 12.5 kSps sample rate
- Flexible 2.2 to 3.6 V supply range
- Low 4 mA typical supply current
- Full -40 °C to 125 °C operating range

Block Diagram

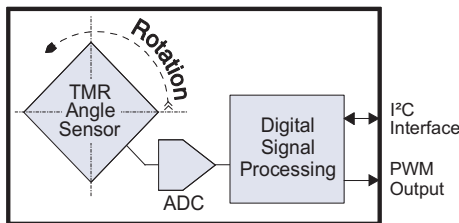

Applications

- Rotary encoders
- Robotics
- Motor control
- Automotive applications
- Internet of Things (IoT) end nodes

Description

ASR012 TMR Smart Angle Sensors provide a precise digital angle measurement over a wide range of speeds.

The sensor combines precise, low-power Tunneling Magnetoresistance (TMR) sensing elements with sophisticated digital signal processing.

The sensor is factory calibrated, with coefficients stored in internal memory.

An I²C interface provides angle data and allows setting device parameters. A PWM output also provides angle data.

The ASR012 is designed for harsh industrial or automotive environments with ESD protection, and full -40 °C to 125 °C operating temperature range.

Transfer Function

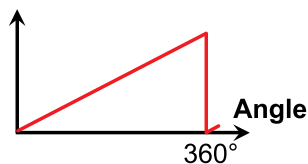

Boundary Ratings

Parameter	Min.	Max.	Units
Supply voltage	-12	4.2	Volts
Input and output voltages (MISO, MOSI, SS, SCLK)	-0.5	$V_{cc}+2.5$ up to 5.8	Volts
Input current	-100	+100	mA
Storage temperature	-55	150	°C
ESD (Human Body Model)		2000	Volts
Applied magnetic field		Unlimited	Tesla

Operating Specifications (T_{min} to T_{max} ; $2.2 < V_{DD} < 3.6$ V unless otherwise stated)

Parameter	Symbol	Min.	Typ.	Max.	Units	Test Condition
Operating temperature	$T_{min}; T_{max}$	-40		125	°C	
Supply voltage	V_{DD}	2.2		3.6	V	
Supply current	I_{DD}		4	6	mA	Max. at $V_{DD} = 3.6$ V
Power-on Reset supply voltage	V_{POR}		1.4		V	
Brown-out power supply voltage	V_{BOR}	0.75	1	1.36	V	
Start-up time	T_{STA}		15		ms	
Magnetics						
Applied magnetic field strength	H	6	12	20	mT	
Accuracy and Repeatability						
Angular resolution	δ		0.1		Angular Degrees	Fixed temperature and bias ¹
Angular hysteresis	\square			0.1		
Repeatability			± 0.2			
Angular accuracy, fixed bias ¹	ϵ			± 2		
Angular accuracy, variable bias ²				± 3		
				± 6		-40 to 125°C
Speed						
Sample rate			12.5		kSps	
PC Interface						
Data transfer rate	DR			400	kBaud	
Bus voltage	V_{BUS}	2.2		5.5	V	
Output response and transmission times				20	μ s	400 kBaud
Low level input threshold voltage	V_{IL}	0.8			V	
High level input threshold voltage	V_{IH}			2.2	V	
Low level output current	I_{OL}	3			mA	$V_{OL} = 0.4$ V
I/O capacitance	$C_{I/O}$			10	pF	
PWM Output						
PWM frequency			24		kHz	
RAM Timing						
Address setup time	t_{ADDR}	3			μ s	See figure 4
Data read time	t_{READ}	10			μ s	
Nonvolatile Memory Characteristics						
Address setup time	t_{ADDR}	3			μ s	See figure 5
Data read time	t_{READ}	10			μ s	
Data write time	t_{NVM}	20			ms	
Endurance			10000		Cycles	
Package Thermal Characteristics						
Junction-to-ambient thermal resistance	θ_{JA}		320		°C/W	
Package power dissipation			500		mW	

Specification Notes:

1. “Fixed Bias” means a fixed airgap within between the bias magnet and sensor so the magnitude of the magnetic field at the sensor is constant within the specified field range of the parts. The highest accuracy is obtained using fields closest to the 17.5 mT factory calibration field.
2. “Variable Bias” means the magnitude of the magnetic field at the sensor can vary across the entire specification range.

ASR012 Overview

The ASR012 is a non-contact angle sensor designed for high speed applications where size is limited. The heart of the ASR012 is a tunneling magnetoresistive (TMR) sensor. In a typical configuration, an external magnet provides a magnetic field of 6 to 20 mT (60 to 200 Oe) in the plane of the sensor, as illustrated below for a bar magnet and a diametrically-magnetized disk magnet. Factory-programmed signal conditioning is combined with a temperature sensor and digital linearization to produce high speed, accuracy, and precision in a tiny 2.5 x 2.5 mm TDFN package.

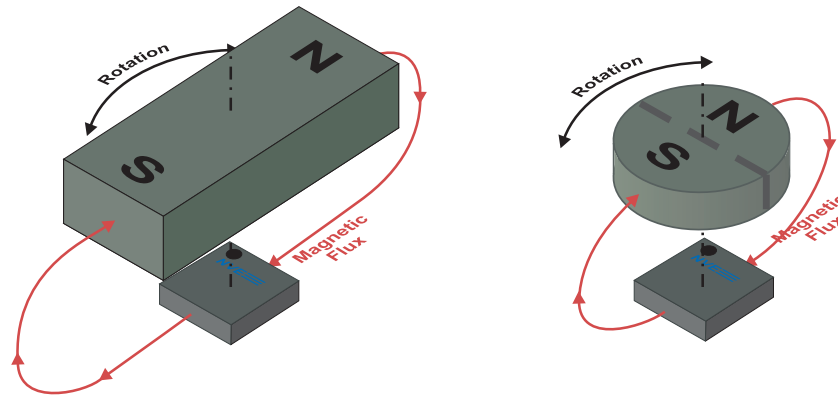

Figure 1. Sensor operation.

ASR012 Operation

A detailed block diagram is shown below:

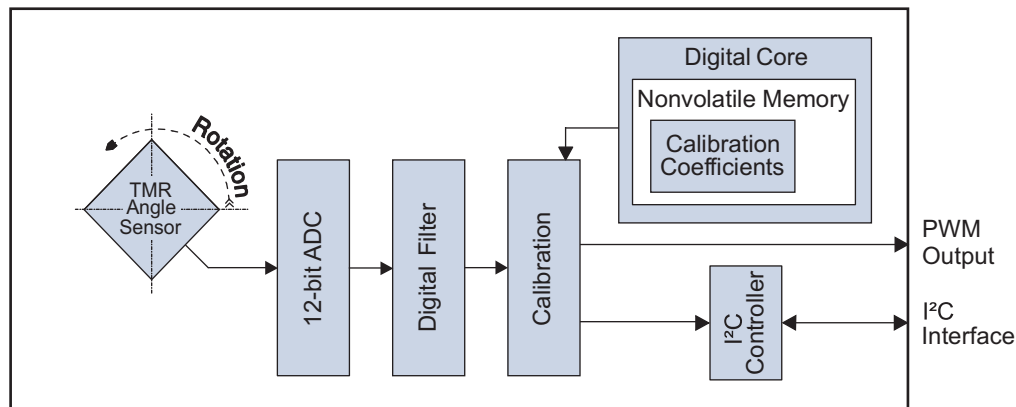

Figure 2. Detailed block diagram.

TMR Angle Sensor Element

ASR0x2 sensors use unique TMR sensor elements that are inherently high speed and low noise. The digital core calculates the angle from sensor element Sine and Cosine vectors, and the raw sensor data are available from separate memory locations.

ADC

The sensor output is digitized with a 12-bit ADC. The extra bits ensure precision and computational accuracy.

Digital Filter

A first-order Infinite Impulse Response (IIR) digital filter with a programmable cutoff frequency can be used for ultralow noise if high-frequency operation is required. The factory default is the filter turned off.

Rotation Direction

The ASR012 can provide increasing angle values for either clockwise or counterclockwise field rotations. Counterclockwise is defined as a rotating field vector through pins 1-3-4-6, and clockwise through pins 1-6-4-3. The rotation direction can be programmed using the θ_{DIR} parameter.

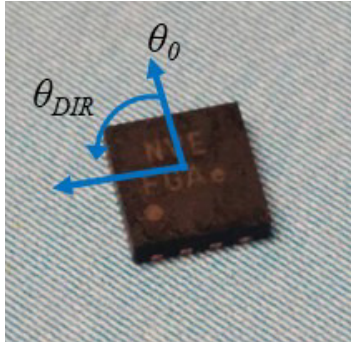

Figure 3. Zero-angle reference (θ_0) and rotation direction (θ_{DIR}). The rotational center of the sensor is the package center.

Zero-Angle Reference Point

A programmable parameter θ_0 sets the zero-degree reference or angular offset. This is the angle of “discontinuity,” that is, where the angle output changes from 360° to 0°. The default θ_0 value is zero for magnetic fields pointing from pin 1 to pin 6.

Direction and Hysteresis

The Direction output indicates direction of rotation. A hysteresis setting can be changed to prevent small changes from causing the Direction output to “chatter,” especially at low speed.

Digital Filter

The digital filter is an Infinite impulse response (IIR) weighted running average filter, which can reduce mechanical and electrical noise depending on the required speed.

The filtered output is calculated as follows:

$$\theta_n = \theta/m + [(m-1)/m]\theta_{n-1}$$

Where θ = is the measured angle; θ_n = the filtered angle; θ_{n-1} is the previous value of the filtered angle; and m is a constant that determines the cutoff frequency as follows:

$$f_{CUTOFF} = f_{SAMPLE}/(2\pi m)$$

Where f_{CUTOFF} is the filter cutoff frequency and f_{SAMPLE} is the sensor ADC sampling rate (approximately 12500/s). So for example, if $m = 10$, the cutoff frequency is approximately 200 Hz.

$m = 1$ disables filter so the output is simply updated with each sample.

I²C Interface

Changing the I²C Address in Nonvolatile Memory

The default I²C address is stored in nonvolatile memory, and can be changed like any other parameter. The I²C standard reserves certain addresses, so recommended I²C addresses are 16 to 238 (0x10 to 0xEE hex).

Note that if there are multiple ASR012's on the same I²C bus there will be a collision before addresses can be changed. Therefore changing the address in this way may require a single-sensor programming setup.

Overriding the I²C Address with an External Jumper

Grounding the I²C address override pin ("I2CADDR") changes the I²C address to 16 dec regardless of the programmed address. Leaving the pin open or tied HIGH invokes the I²C address in nonvolatile memory, which is 72 dec by default but can be reprogrammed by the user in memory location 0x44. The pin is checked only on power-up.

Eight-Bit I²C Address

In accordance with industry standards, ASR012 sensors have eight-bit I²C addresses (seven bits plus an R/W bit). Some I²C Master devices (such as Arduinos) send seven-bit addresses. In this case, the sensor address should be divided by two, so for example a default I²C address of 36 rather than 72 would be used.

Reading and Writing the Sensor Memory

Data is read by first writing an address byte to the sensor (with the I²C Read/Write bit set to "Write"). Subsequent I²C read commands will return the data or parameter in the active address.

The default memory address is 0, which is the calibrated sensor output, so "out of the box" the sensor output can simply be retrieved with I²C read commands.

Reading the Angle

To read the angle, the master simply writes zero for the "0" angle address, then reads the two-byte angle, which is expressed in tenths of degrees. The active address will remain the same until changes, so the angle can be read repeatedly without writing the address each time.

Reading and Writing Parameters

Reading and writing parameters are simple three-byte sequences. The master writes a byte for the parameter address, then reads or writes two bytes for the parameter value.

The number of bits in different parameters varies. Unused bits are sent as zeros by the sensor. Similarly, unused bits should be written as zeros to the sensor to avoid an out-of-range parameter that could be ignored.

Because of the slower speed of the sensor's nonvolatile memory, allow 15 ms for parameter writes.

PWM Analog Output

The PWM output tracks the measured angle and can be externally filtered as an analog output. The output is ratiometric with the power supply, i.e., equal to V_{DD} at 360°, so the output is 9.2 mV per degree with a 3.3 V supply.

Memory Map

The ASR012 memory provides access to angle data and user-programmable parameters. The memory is accessed via I²C.

Parameter	Symbol	Default	Read/Write	Range	Address	Description
Data						
Angle	θ	N/A	R	0 – 3600	0x00	In tenths of a degree
Raw Sin Vector	Sin θ			Approx. 1500 – 2500	0x01	Raw outputs centered at approx. 2048 with peak-peak amplitudes of approx. 1000.
Raw Cos Vector	Cos θ				0x02	
Direction	Dir			0 – 1	0x03	0 = decreasing angle 1 = increasing angle
User-Programmable Parameters						
Rotation Direction	θ_{DIR}	0	R/W	0 – 1	0x40 [bit 0]	0 → increasing CCW; 1 → increasing CW (see Fig. 3)
Angular Offset	θ_0	0		0 – 3600	0x41 [bits 13:0]	Point at which angle is zero (see Fig. 3)
Digital Filter Constant	m	1		1 – 255	0x42	$f_{CUTOFF} = f_{SAMPLE} / (2\pi m)$; $f_{SAMPLE} = \text{approx. } 12.5 \text{ kSps}$ m = 1 disables filter
Direction Hysteresis	δ_{DIR}	25		0 – 255 (0 – 25.5°)	0x43	Hysteresis of the “Dir” output; in tenths of a degree
I ² C address	I2CADDR		R/W	16 to 238 (0x10 to 0xEE)	0x44	I2CADDR with pin 1 floating or HIGH
Read-Only Memory						
Lot code	YY	N/A	R	N/A (ASCII)	0x80	ASCII date code in the form YYWWXX, where: YY = year; WW = work week; XX = internal code.
	WW				0x81	
	XX				0x82	

Table 1. ASR012 Memory Locations.

Power-Up and Initialization

Absolute position

Unlike some encoder types, ASR0x2 sensors detect absolute position and maintain position information when the power is removed. The sensor powers up indicating the correct position.

Nonvolatile parameters

All parameters are nonvolatile so they can be set once (via I²C), and remain for the life of the product if desired.

Minimizing Magnetic Interference

Several precautions can be taken for applications requiring the best accuracy to avoid distorting the magnetic field at the sensor:

- Components such as resistors and capacitors are generally slightly magnetic, and should be located at least several millimeters from the sensor.
- If components must be located near the sensor, ultrasmall components such as 0201 (0603 metric) contain less ferromagnetic material than larger components.
- Nonmagnetic resistors and capacitors can be used for extremely sensitive applications. A nonmagnetic 0.1 μ F bypass capacitor can be used close the sensor, with a conventional 10 μ F ceramic capacitor at least several millimeters away.

Minimizing Noise

Several steps minimize noise:

- Inadequate bypassing can cause noise or anomalous device behavior. 10 μ F total bypass capacitance is recommended. To minimize magnetic field disruption, a small (e.g., 0201 / 0603 metric) 0.1 μ F ceramic capacitor can be placed as close as possible to the V_{DD} and GND pins with a 10 μ F ceramic capacitor a few millimeters away. The small capacitors contain very little ferromagnetic material.
- Use a circuit board ground plane.
- If the sensor is not being used for current over trace sensing, ground the sensor's center pad so the leadframe acts as a shield.

Magnet Selection

The sensor’s wide operating field range of 6 to 20 mT (60 to 200 Oe) allows inexpensive magnets and operation over a wide range of magnet spacing. The figures below show the magnetic field for various magnet geometries and distances for inexpensive C5/Y25 grade ferrite magnets:

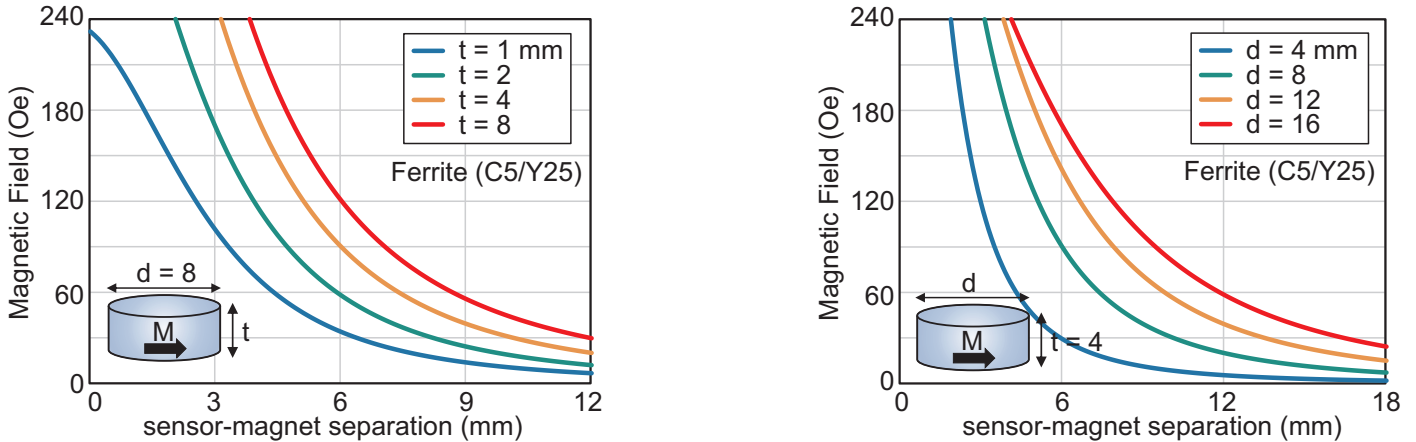

Figure 8. Magnetic fields for various geometries of C5/Y25 ferrite magnets plotted for the distance between the magnet and sensor. Eight-millimeter diameter magnets of various thicknesses are shown at left, and four-millimeter thick magnets of various diameters are shown at right.

Field varies less with distance for larger magnets, so maximizing magnet size within the mechanical constraints of the system maximizes accuracy.

Higher-grade magnets can be used for high-temperature applications or large magnet-sensor separations. The graph below shows field strengths with various materials:

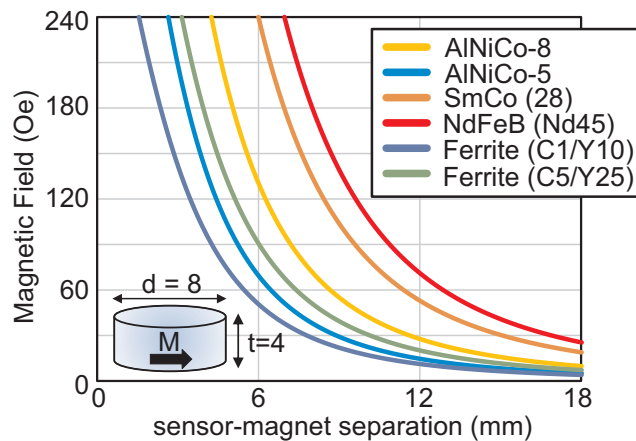

Figure 9. Magnetic fields from an 8 millimeter diameter, 4 millimeter thick magnet for increasing magnet-sensor separation. NdFeB materials produce the largest magnetic fields and separations. SmCo and AlNiCo materials offer the highest operating temperatures. Ferrite magnets are the most cost-effective.

Our free Web app can be used to determine optimum separations for various magnet sizes and materials:

<https://www.nve.com/spec/calculators.php>.

[NVE’s Online Store](#) stocks popular magnets.

Application Circuits

Typical Microcontrollers Interface

A typical microcontroller interface is shown below:

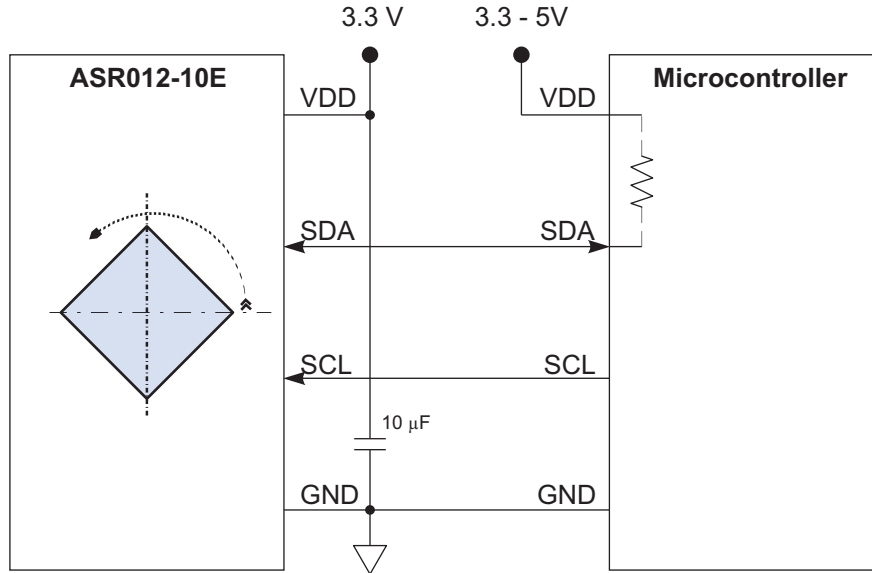

Figure 10. Typical microcontroller interface.

The ASR012 is configured as a Slave and the microcontroller should be configured as the Master. The ASR012 I²C interface is compatible with 3.3 or 5 volt microcontrollers.

The ASR012 SDA line is open-drain, so the microcontroller's internal pull-up resistor should be activated in software. If an external pull-up is used with different power supplies, it should be connected to the lower supply voltage, which is generally the sensor supply.

Double Isolation Circuit

Double isolation from human interface to line-voltage driven electrical circuitry is required in some safety intensive applications such as medical instruments. The mechanical gap between the magnet and the sensor can provide one level of isolation from a knob or other human interface. Galvanic isolation from the sensor to the microcontroller provides a second isolation barrier:

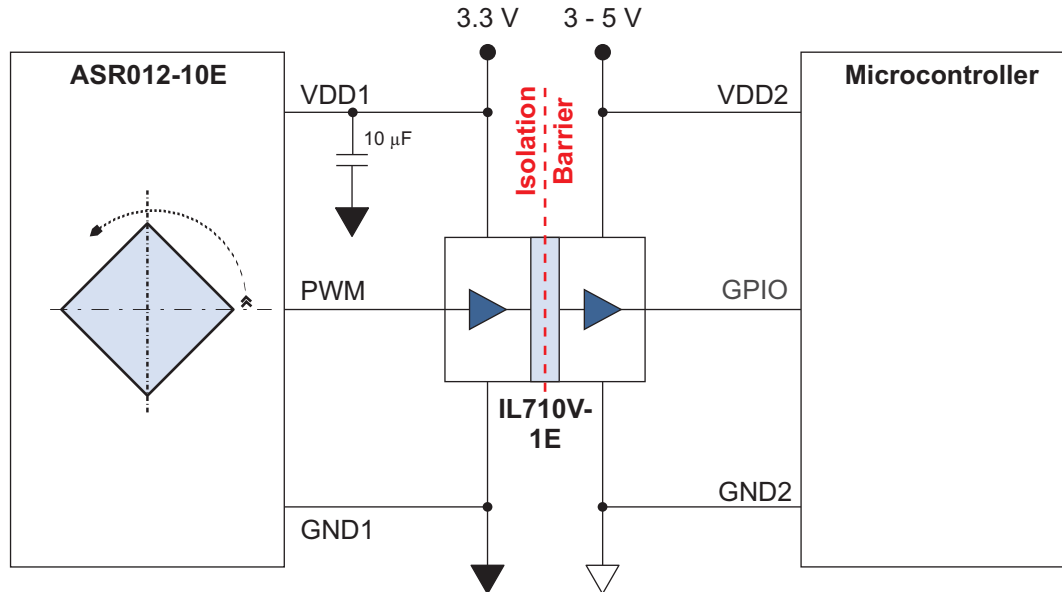

Figure 11. Double-isolated microcontroller interface.

Since it is single-channel and unidirectional, the PWM output can be easily isolated with just a single-channel digital isolator. The I²C interface is more complex and expensive to isolate since there are two bidirectional, open-drain lines.

The IsoLoop IL710V-1E isolator in the circuit above is a UL/VDE-compliant, ultra-miniature MSOP galvanic isolator with a 2.5 kV isolation rating. The isolator can also level-shift between the 3.3-volt sensor and a five-volt microcontroller.

The PWM signal can be decoded by the microcontroller using commonly-available routines.

There may be inaccuracies at angles close to zero if the PWM pulses are too narrow to be detected by the microcontroller.

Filtered PWM Read by an Analog Input

If speed is not critical, the isolated PWM signal can be filtered with a resistor and capacitor and connected to a microcontroller analog input. This provides accurate readings at all angles, including angles close to zero.

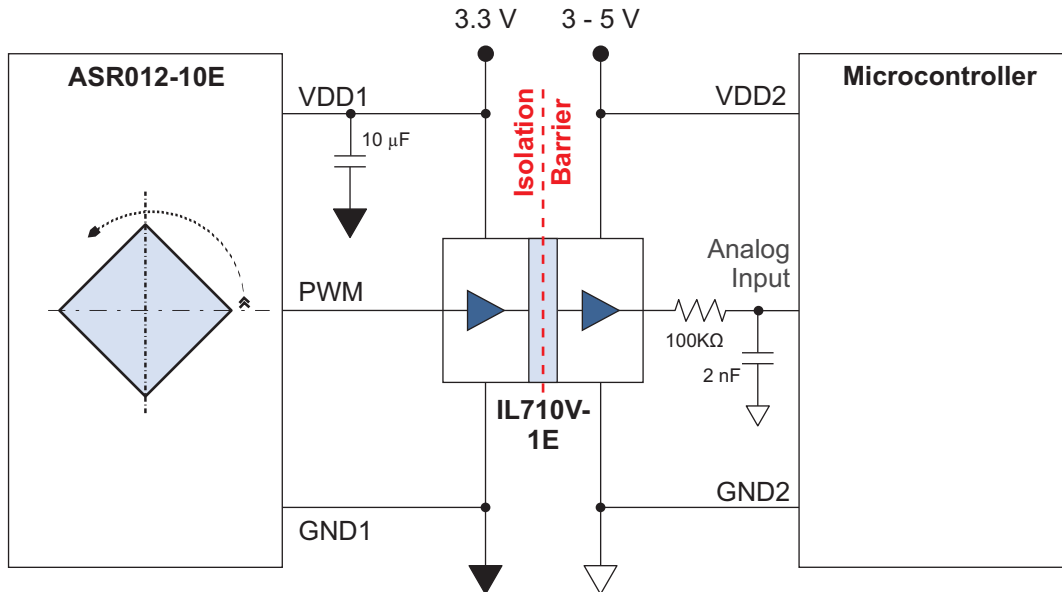

Figure 12. Filtered PWM read by a microcontroller analog input.

The 100 kΩ resistor avoids loading the isolator output while providing a low enough impedance for most microcontroller analog inputs. The 2 nF filter capacitor yields a 200 µs time constant, which is adequate to filter the sensor's 24 kHz PWM output. The resultant cutoff frequency is approximately 31 kHz.

Illustrative Arduino Code for Continuously Reading Angles

```
//Reads ASR012 angle via I2C via an Arduino Uno. SDA-->A4; A5-->SCL
#include <SPI.h>
int angle; //Sensor output (tenths of a degree)

void setup() {
Wire.begin(); //Join I2C bus as Master
}
void loop() {
Wire.requestFrom(36,2); //Request two bytes from sensor (I2C address 72/2=36)
angle = Wire.read()<<8; //Read angle MSB
angle |= Wire.read(); //Read angle LSB
delay(200); //5 samples per second
}
```

Pseudo Code for I²C Reading and Writing

```

uint16_t read_from_sensor(uint8_t ASR012_i2c_address, uint8_t read_location_address)
{
    while (!i2c_start(ASR012_i2c_address)) i2c_stop(); //spins till bus is available to
    start
    i2c_write(read_location_address);
    i2c_stop();
    while (!i2c_rep_start((ASR012_i2c_address) | 0x01)); // write the address of the sensor
    with the read bit set
    uint8_t MSB = i2c_read(0); //MSB read from bus, no nack
    uint8_t LSB = i2c_read(1); //LSB read from bus, nack to notify sensor that transfer is
    done
    i2c_stop(); //read is complete

    return (MSB << 8) | LSB;
}

void write_to_sensor(uint8_t ASR012_i2c_address, uint8_t write_location_address,
uint8_t MSB, uint8_t LSB){

    while (!i2c_start(ASR012_i2c_address) i2c_stop()); //spins till bus is available
    to start

    i2c_write(write_location_address); //sensor write location is written to the bus
    i2c_write(MSB); //MSB first
    i2c_write(LSB); //LSB second
    i2c_stop(); //write is complete
    delay(15); 15 ms delay after write to nonvolatile memory
}

```

Evaluation Support

Breakout Board

The AG957-07E breakout board provides easy connections to an ASR012-10E angle sensor with a six pin connector. It also has a recommended 10 μ F bypass capacitor:

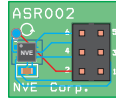

Figure 13. ASR012 breakout board (actual size)
0.5" x 0.6" (12 mm x 15 mm)

Smart Angle Sensor Evaluation Kit

This simple board includes an ASR012-10E Smart Angle Sensor, a microcontroller that interfaces to the Sensor via I²C, and to a PC via USB. The kit includes a diametrically-magnetized cylindrical horseshoe magnet and fixturing. A PC-based user interface provides two-way communication with the sensor to display the sensor outputs and change the sensor's parameters.

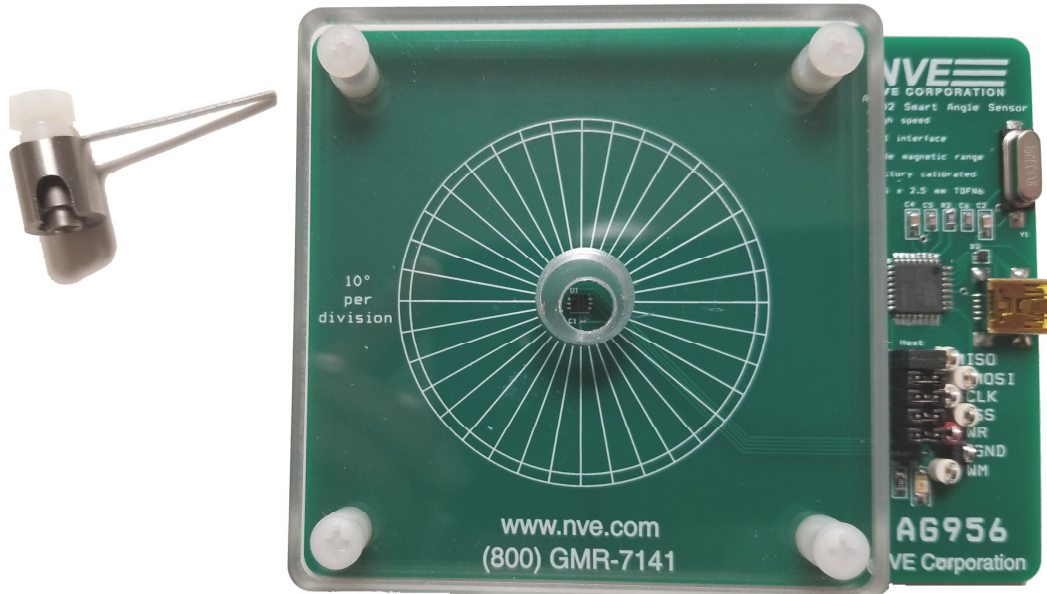

Figure 14. ASR012 Smart Angle Sensor Evaluation Kit.

Socket Board

The AG954-07E provides a TDFN6 socket for easy interface to sensors such as the ASR012-10E without soldering:

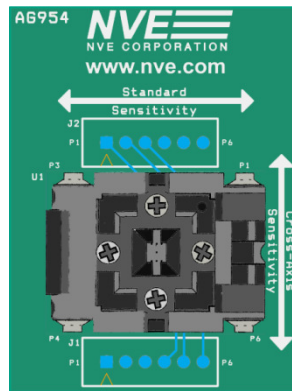

Figure 15. AG954-07E: TDFN socket board
1.5" x 2" (38 mm x 50 mm)(actual size)

Magnets

NVE stocks five popular magnets for use with its angle sensors:

NVE Part Number	Compatible Magnet Holder	Diameter (mm)	Length (mm)	Typ. sensor distance (mm; 12 mT nom. field)	Material and Configuration
12526	4 mm	4	4	3	C5/Y25 ferrite disk magnets
12249	N/A	12.5	3.5	4	
12527	8 mm	8	4	5	
12528	8 mm	8	8	6	
12426*	N/A	11	11	8	Alnico-5 round horseshoe magnet with mounting hole

*Included in the Smart Angle Sensor Evaluation Kits.

Table 2. Popular magnets for angle sensing.

Magnet Holders

NVE offers two magnet holders for evaluation and prototyping. The holders are machined aluminum. Set screws secure the magnets in the holders and allow magnet position adjustments. There are threaded mounting holes for a thumbscrew to turn the magnet, or the hole can be used to attach the holder to a rotating shaft. A “clockhand” indicator helps track magnet rotation:

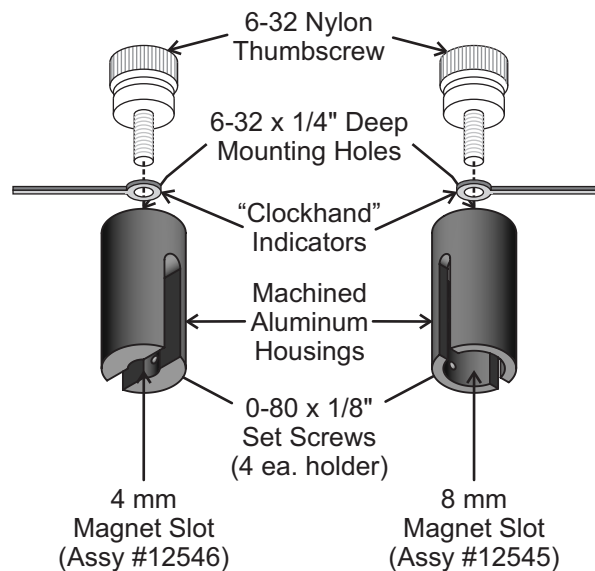

Figure 16. Four millimeter magnet holder (part #12546; left) and 8 mm magnet holder (part #12545; right). 0.44" dia. x 0.88" tall (11 mm x 22 mm) outside dimensions; actual size).

The holders are compatible with several popular diametrically-magnetized disk magnets and can be used in Smart Angle Sensor Evaluation Kits:

Holder Part Number	Outside Dimensions	Compatible Magnets (NVE part #s)	Magnet Diameter (mm)	Max. Magnet Length (mm)
12546	11 mm dia. x 22 mm tall	12526	4	4
12545		12527; 12528	8	8

Table 3. Magnet holders.

2.5 x 2.5 mm TDFN6 Package

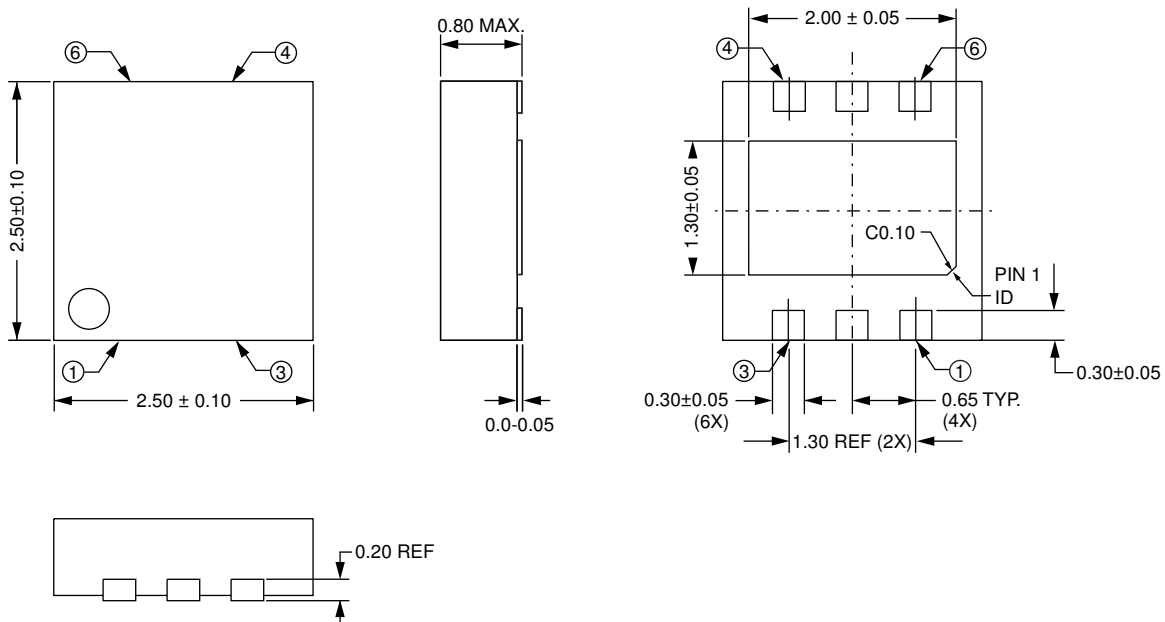

Pad	Symbol	Description
1	GND	Ground/ V_{SS}
2	SDA	I ² C Data (bidirectional; open drain)
3	SCL	I ² C Clock (input)
4	VDD	Power Supply (bypass with a 10 μ F capacitor)
5	PWM	PWM Output
6	I2CADDR	I ² C address override (LOW-true input; read on power-up). Grounding this pin changes the I ² C address to 16 dec regardless of the programmed address. Open or HIGH invokes the I ² C address in nonvolatile memory.
Center pad		Internal leadframe connection; connect to GND to minimize noise.

Notes:

- Dimensions in millimeters.
- Soldering profile per JEDEC J-STD-020C, MSL 1.



Ordering Information

ASR012 - 10E TR13

Product Family

ASR = Smart Angle Sensors

I/O

00 = SPI

01 = I²C

Sensor Element

2 = High speed, medium accuracy

Field Range Identifier

Blank = General Purpose (6 to 20 mT / 60 to 200 Oe)

Part Package

10E = RoHS-Compliant 2.5 x 2.5 mm TDFN6 Package

Bulk Packaging

TR13 = 13" Tape and Reel Package

Available Product Variants

Part Number	Evaluation Kit	Repeatability	Speed	Outputs
ASR002-10E	AG956-07	0.2°	12500 Sps	SPI
ASR012-10E	AG963-07			I ² C; PWM

Revision History

SB-00-081-RevA

January 2020

Changes

- Added application diagrams.
- Added illustrative Arduino code and I²C pseudocode.
- Moved I2CADDR parameter memory address.
- Initial release.

SB-00-081-PRELIM

December 2019

Change

- Preliminary release.

Datasheet Limitations

The information and data provided in datasheets shall define the specification of the product as agreed between NVE and its customer, unless NVE and customer have explicitly agreed otherwise in writing. All specifications are based on NVE test protocols. In no event however, shall an agreement be valid in which the NVE product is deemed to offer functions and qualities beyond those described in the datasheet.

Limited Warranty and Liability

Information in this document is believed to be accurate and reliable. However, NVE does not give any representations or warranties, expressed or implied, as to the accuracy or completeness of such information and shall have no liability for the consequences of use of such information.

In no event shall NVE be liable for any indirect, incidental, punitive, special or consequential damages (including, without limitation, lost profits, lost savings, business interruption, costs related to the removal or replacement of any products or rework charges) whether or not such damages are based on tort (including negligence), warranty, breach of contract or any other legal theory.

Right to Make Changes

NVE reserves the right to make changes to information published in this document including, without limitation, specifications and product descriptions at any time and without notice. This document supersedes and replaces all information supplied prior to its publication.

Use in Life-Critical or Safety-Critical Applications

Unless NVE and a customer explicitly agree otherwise in writing, NVE products are not designed, authorized or warranted to be suitable for use in life support, life-critical or safety-critical devices or equipment. NVE accepts no liability for inclusion or use of NVE products in such applications and such inclusion or use is at the customer's own risk. Should the customer use NVE products for such application whether authorized by NVE or not, the customer shall indemnify and hold NVE harmless against all claims and damages.

Applications

Applications described in this datasheet are illustrative only. NVE makes no representation or warranty that such applications will be suitable for the specified use without further testing or modification.

Customers are responsible for the design and operation of their applications and products using NVE products, and NVE accepts no liability for any assistance with applications or customer product design. It is customer's sole responsibility to determine whether the NVE product is suitable and fit for the customer's applications and products planned, as well as for the planned application and use of customer's third party customers. Customers should provide appropriate design and operating safeguards to minimize the risks associated with their applications and products.

NVE does not accept any liability related to any default, damage, costs or problem which is based on any weakness or default in the customer's applications or products, or the application or use by customer's third party customers. The customer is responsible for all necessary testing for the customer's applications and products using NVE products in order to avoid a default of the applications and the products or of the application or use by customer's third party customers. NVE accepts no liability in this respect.

Limiting Values

Stress above one or more limiting values (as defined in the Absolute Maximum Ratings System of IEC 60134) will cause permanent damage to the device. Limiting values are stress ratings only and operation of the device at these or any other conditions above those given in the recommended operating conditions of the datasheet is not warranted. Constant or repeated exposure to limiting values will permanently and irreversibly affect the quality and reliability of the device.

Terms and Conditions of Sale

In case an individual agreement is concluded only the terms and conditions of the respective agreement shall apply. NVE hereby expressly objects to applying the customer's general terms and conditions with regard to the purchase of NVE products by customer.

No Offer to Sell or License

Nothing in this document may be interpreted or construed as an offer to sell products that is open for acceptance or the grant, conveyance or implication of any license under any copyrights, patents or other industrial or intellectual property rights.

Export Control

This document as well as the items described herein may be subject to export control regulations. Export might require a prior authorization from national authorities.

Automotive Qualified Products

Unless the datasheet expressly states that a specific NVE product is automotive qualified, the product is not suitable for automotive use. It is neither qualified nor tested in accordance with automotive testing or application requirements. NVE accepts no liability for inclusion or use of non-automotive qualified products in automotive equipment or applications.

In the event that customer uses the product for design-in and use in automotive applications to automotive specifications and standards, customer (a) shall use the product without NVE's warranty of the product for such automotive applications, use and specifications, and (b) whenever customer uses the product for automotive applications beyond NVE's specifications such use shall be solely at customer's own risk, and (c) customer fully indemnifies NVE for any liability, damages or failed product claims resulting from customer design and use of the product for automotive applications beyond NVE's standard warranty and NVE's product specifications.

An ISO 9001 Certified Company

NVE Corporation
11409 Valley View Road
Eden Prairie, MN 55344-3617 USA
Telephone: (952) 829-9217
www.nve.com
e-mail: sensor-info@nve.com

©NVE Corporation
All rights are reserved. Reproduction in whole or in part is prohibited without the prior written consent of the copyright owner.

SB-00-081_ASR012-10_RevA

January 2020