

Quartz Crystal

Series 6B, Resistance Welded HC-49/S Package



Approved by:	
Checked by :	
Issued by:	

SPECIFICATION

MODEL: SJK-6B-14.7456-16-30-50-F-B-30-H

深圳市晶科鑫实业有限公司

SHENZHEN CRYSTAL TECHNOLOGY INDUSTRIAL CO., LTD.

Add: RM#:1805East Wing,TianAn Hi-tech Plaza Phase2,TianAn Cyber Park, Shenzhen, China

Tel: (86) 755 88352809 88352810 Fax: (86) 755 88353718 88352499

E-mail: jolly@q-crystal.com HTTP://www.q-crystal.com

Quartz Crystal



Series 6B, Resistance Welded HC-49/S Package

FEATURE

- I Height 3.5mm, The volume is compact at about one –fourth of the former product(HC-49U)
- I A resistance weld completely sealed type
- I The frequency stability is good ,the reliability is high
- I Copes with high density mounting and is the is the optimum for mass production

ELECTRICAL SPECIFICATIONS

Nominal frequency	14.7456MHz
Oscillation mode	Fundamental
Load capacitance	16PF
Frequency tolerance	± 30 PPM at $25 \pm 3^{\circ}\text{C}$
Equivalent series resistance	50 Ω
Storage temperature range	-40°C -- $+85^{\circ}\text{C}$
Operating temperature range	-20°C -- $+70^{\circ}\text{C}$
Frequency Stability Over Operating Temperature	± 30 PPM
Parallel capacitance(C_0)	7PF Max
Drive level	10 μW
Insulation resistance	More than 500M Ω AT DC100V
Shock Resistance	Drop test of 3times on 2mm stainless plate from 75cm height
Aging (at 25 $^{\circ}\text{C}$)	± 5 PPM/year Maximum

Add: RM#:1805East Wing,TianAn Hi-tech Plaza Phase2,TianAn Cyber Park, Shenzhen, China
Tel: (86) 755 88352809 88352810 Fax: (86) 755 88353718 88352499
E-mail: jolly@q-crystal.com HTTP://www.q-crystal.com

Quartz Crystal



Series 6B, Resistance Welded HC-49/S Package

Dimension

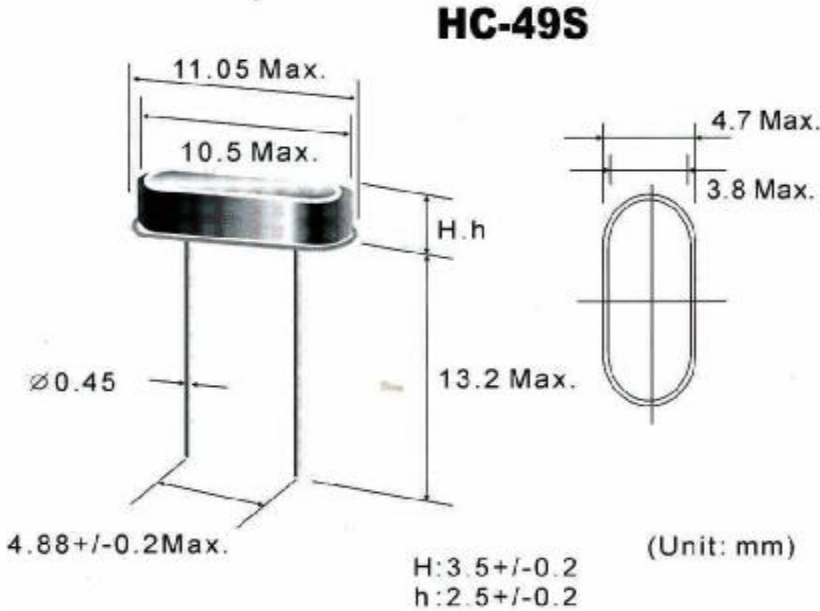

Wave soldering temperature curve

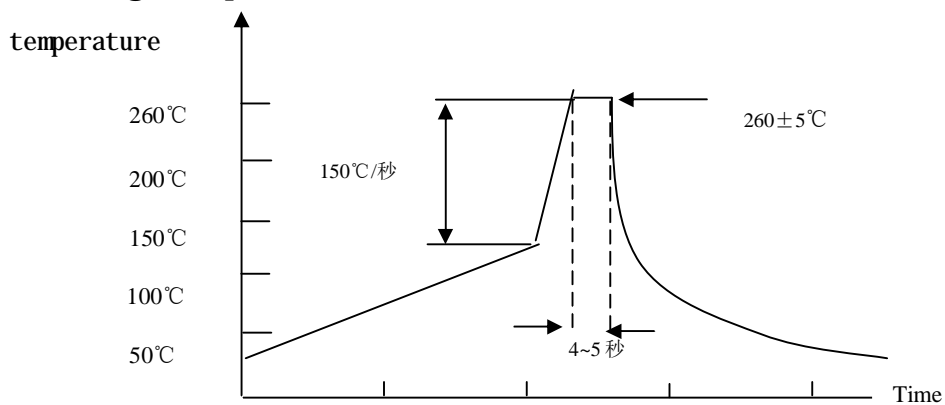

PART NUMBER

SJK-14.7456	16	30	50	F	B	30	H
6B-Frequency 14.7456MHz	Load capacitance 16pf s: series	Frequency tolerance ±30ppm	E.S.R.max e.g. 50Ωmax	oscillate mode F:Fundamental 3:3rd overtone 5:5th overtone	operating temperature range A:-10-60°C B:-20-70°C C:-40-85°C	temperature stability: ±30ppm	H:Normal (3.5mm) h:low (2.5mm)

Add: RM#:1805East Wing, TianAn Hi-tech Plaza Phase2, TianAn Cyber Park, Shenzhen, China
 Tel: (86) 755 88352809 88352810 Fax: (86) 755 88353718 88352499
 E-mail: jolly@q-crystal.com HTTP://www.q-crystal.com

Quartz Crystal

Series 6B, Resistance Welded HC-49/S Package



RELIABILITY TEST SPECIFICATION

Test item	Equipment	Condition	Specification
1. TERMINAL STRENGTH TEST	Pull equipment	1.10N FORCE IN AXES OF TERMINATION 10±1SEC 2.2.5MM FROM TERMINAL, BEND 90°	'1. MIL-STD-202F,METHOD 211A
2.SOLDERABILITY TEST	SJK-REL001 、 RC-328A	1.solderability:235±5℃, 5±0.5S 2.heat resistance:260±5℃,10±1S restoration of 1 hour	'1. MIL-STD-883CMETHOD 2003.7 2. MIL-STD-202F,METHOD 210A
3. HERMETICITY TEST	UL-306S	small and do not control roughly (hubble-bubble machine); Nothing air bubble creation s thin leave out 1 * 10 E-8 ATM.CC/SEC.	MIL-STD-883C METHOD 1014.9
4. VIBRATION TEST	HG-V4、S&A 250B	Enable Crystal(10g) from 10-55-10Hz,X、Y、 Z horizontal,1 Minute vibration/time, 1time/ 2 hours.	JIS C5025 TEST A MIL-STD-883C,METHOD 2007.2
5. MECHANICAL SHOCK	HPC-200、S&A 250B	Enable Crystal 50G(490m/s ²) time=11 ms speed=3.4 m/s half sine wave oscillation	JIS C5026 MIL-STD-883C,METHOD 2002
6. DROP TEST	HARD BOARD.S&A250B	75CM HIGH,3 TIMES ON HARD BOARD	'JIS C6701
7. SALT SPRAY	H-SST-60、 RC-328A	5% NaCL,35℃±2℃ CHAMBER,48 hrs. , PH:6.5~7.2	JIS C5028 & MIL-STD-202FMETHOD 101D
8. HIGH&LOW TEMP STORAGE TEST(Static test)	H-PTH-80CK & HM101-3ABN , S&A 350B/250B	High temperature: 125℃±2℃,1000hr; Low temperature:-40℃±3℃,1000hrs	MIL-STD-883C,METHOD 1011.8& JIS C5030
9. TEMP & HRM CYCLING TEST	H-PTH-80CK CHAMBER , S&A 350B/250B	Temperature:-10 ℃ ±2 ℃ ~ 65 ℃ ±2℃,Humidity:93±3%,1 cycle need 24 hrs. 5cycles.	MIL-STD-883C,METHOD 1010.7
10. HIGH TEM. & HUM. STORAGE TEST	H-PTH-80CK CHAMBER , S&A350B/250B	temperature:40 ℃ ±2 , Humidity:85+3,-2%,Store 96 hrs	JIS C5023
11. AGING TEST	H-PTH-80CK CHAMBER , S&A350B/250	temperature: 85℃±2, 1000hrs	JIS C5031

Add: RM#:1805East Wing,TianAn Hi-tech Plaza Phase2,TianAn Cyber Park, Shenzhen, China
Tel: (86) 755 88352809 88352810 Fax: (86) 755 88353718 88352499
E-mail: jolly@q-crystal.com HTTP://www.q-crystal.com