

Passive components Sales Office

• Head Office

206, Cheomdansaneop Road,
Youngtong-gu,
Suwon, Kyonggi Province 443-743,
Korea

Europe

Tel: +82-31-210-6803
E-mail: wesley.roh@samsung.com

America

Tel: +82-31-210-6794
E-mail: randy.kim@samsung.com

Asia

Tel: +82-31-210-5348
E-mail: koogi@samsung.com

Domestic

Tel: +82-31-210-3757
E-mail: southjoy@samsung.com

• Manufacturing Site

Suwon Plant

206 Cheomdansaneop Road,
Youngtong-gu,
Suwon, Kyonggi Province 443-743,
Korea
Tel: +82-31-210-6794
E-mail: randy.kim@samsung.com

Busan Plant

1623-2, Songjeong-dong,
Kangseo-gu, Busan 618-270, Korea
Tel: +82-51-970-7671
E-mail: kyc.kweon@samsung.com

Tianjin Plant

27, Heiniu, Cheng-Road, Tianjin,
China 300210
Tel: +86-22-2830-3333(3450)
E-mail: gk.ryu@samsung.com

Philippines Plant

Calamba Premiere International Park,
Batino, Calamba, Laguna, Manila
Tel: +63-2-809-2873
E-mail: ksj1445@samsung.com

• Asia sales office

Shanghai Office

Rm 1408 Shanghai international
trade center No 2200 Yan an(W) RD
Shanghai China 200335
Tel: 86-21-6270-4168(274)
E-mail: dennis.cha@samsung.com

Shenzhen Office

Rm 4501, 45/F, New World Center,
Yitian Road, Futian District,
Shenzhen, China 518026
Tel: 86-755-8608-5581
E-mail: jackson.xian@samsung.com

Qingdao Office

Rm 1201, Growne Plaza Qingdao;
76XiangGangZhong Rd, Qingdao;266071
P.R. China
Tel: 86-532-5779102
E-mail: zhengguo.cui@samsung.com

HongKong Office

Suite 4511, Two int'l Finance Centre,
8 Finance Street, Central, Hongkong
Tel: 852-2862-6350
E-mail: vinsent.chou@samsung.com

Singapore Office

3 Church Street Samsung Hub
#23-02 Singapore 049483
Tel: (65)6833-3228
E-mail: winson.yeong@samsung.com

Thai Office

Wellgrow Industrial Estate,
93 Moo 5 T. Bangsamak, A.Bangpakong
Chachoengsao 24180 Thailand
Tel: 66-38-562-026
E-mail: sbimm@samsung.com

Taiwan Office

399 9F-1, Ruey Kuang Rd., Neihu,
Taipei, Taiwan
Tel: 886-2-2656-8356
E-mail: kevin0130.wang@samsung.com

• America sales office

Irvine Office

92612 3345 Michelson Drive,
Suite 350, Irvine, CA
Tel: 1-949-797-8047
E-mail: sh386.kim@samsung.com

• Europe sales office

Frankfurt Office

D-65824 Samsung Haus am
Knonberger Hang 6 Schwalwach / Ts
Tel: 49-(0)6196-66-7255
E-mail: frank.goebel@samsung.com

Hungary Office

H2310, Szigetszentmiklos, Leshegy u.
2-4, Hungary
Tel: 36-24-551-148
E-mail: jun21c.lee@samsung.com

• Domestic Distributors

KORCHIP INC

#219-8 Gasan-dong, Gumchun-gu,
Seoul, Korea
Tel: +82-2-838-5588
E-mail: hjh0064@korchip.com

CHUNG HAN

#16-96 Hangang-lo 3, Youngsan-Gu,
Seoul, Korea
Tel: +82-2-718-3322
E-mail: bu1230choi@hanmail.net

SAMT

Daekyung Bldg., Daechi-Dong,
Gangnam-Gu, Seoul, Korea
Tel: +82-2-3458-9000
E-mail: info@isamt.com

CHUNGMAC

#53-5 Wonhyolo3 Youngsan-gu,
Seoul, Korea
Tel: +82-2-716-6428~9
E-mail: webmaster@anycam.co.kr

APEXINT

Room #905, C-dong Woorimlion's,
Valley 371-28, Gasan-dong,
Guemcheon-Gu, Seoul, Korea
Tel: +82-2-2026-2610(2)
E-mail: info@apexint.co.kr

January 2008

MULTILAYER CERAMIC CAPACITORS

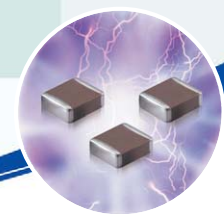



We, Samsung, declare that our component MLCC is produced in accordance with EU RoHS directive.

1. RoHS Compliance and restriction of Br

The following restricted materials are not used in packaging materials as well as products in compliance with the law and restriction.

- Cd, Pb, Hg, Cr+6, As, Br and the compounds, PCB, asbestos
- Bromic materials : PBBs, PBBOs, PBDO, PBDE, PBB

2. No use of materials breaking Ozone layer

The following ODS materials are not used in our fabrication process.

- ODS material : Freon, Haron, 1-1-1 TCE, CCl4, HCFC

If you want more detailed Information, Please Visit Samsung Electro-mechanics Website [<http://www.sem.samsung.com>]

Quality System Certification List

Table 1: Certification list of Samsung Factory

	SUWON(KOREA)	BUSAN(KOREA)	PHILIPPINES	TIANJIN(CHINA)	THAILAND
ISO / TS 16949	BSI TS 91430-001	BSI TS 91430-001	BSI TS 508248		
ISO 9001 (Product)				UL A14163	
TL 9000 (Product)		BSI FM 90588			
ISO 14001	BSI EMS 66454	BSI EMS 66454	BSI EMS 77354	CNAB 02103SI0055ROL	BSI EMS69298
OSHAS 18001	BSI OHS 54734	BSI OHS 54734		CCEMS 012RO	

CONTENTS

Part Numbering System 4

Product Line Up 6

1. General Capacitors
2. Ultra High Capacitors
3. Super Small Capacitors
4. High Voltage Capacitors
5. Array Capacitors
6. Low ESL Capacitors

Packaging Specification 56

Reliability Test Condition 60

1. Appearance
2. Insulation Resistance
3. Withstanding Voltage
4. Capacitance
5. Q Factor / Tan δ
6. Temperature Coefficient of Capacitance
7. Adhesive Strength of Termination
8. Bending Strength
9. Solderability
10. Resistance to Soldering Heat
11. Vibration Test
12. Humidity (Steady State)
13. Moisture Resistance
14. High Temperature Resistance
15. Thermal Cycle
16. Recommended Soldering Method

Application Manual for Surface Mounting 65

1. Recommended Storage Condition
2. Recommended Solder Land Pattern
3. Adhesives
4. Mounting
5. Flux
6. Soldering
7. Notes for Separating Multiple, Shared PC Boards

CL 10 C 101 J B 8 N N N C
1 2 3 4 5 6 7 8 9 10 11

1. SERIES CODE

CL=Multi layer Ceramic Capacitors

2. SIZE CODE — inch(mm)

03=0201(0603) 21=0805(2012) 42=1808(4520)
05=0402(1005) 31=1206(3216) 43=1812(4532)
10=0603(1608) 32=1210(3225) 55=2220(5750)

3. DIELECTRIC CODE

Class I			Class II		
C=COG	S=S2H	L=S2L	A=X5R	F=Y5V	
P=P2H	T=T2H		B=X7R	X=X6S	
R=R2H	U=U2J		Y=X7S		

4. CAPACITANCE CODE

Capacitance expressed in pF. 2 significant digits plus number of zeros.
example) 106=10 × 10⁶=10000000pF
For Values < 10pF, Letter R denotes decimal point
example) 1R5=1.5pF

5. TOLERANCE CODE

A=±0.05pF D=±0.5pF J=±5% Z=+80/-20%
B=±0.1pF F=±1pF, ±1%* K=±10%
C=±0.25pF G=±2% M=±20%

*For Values ≤ 10pF, F=±1pF
Values > 10pF, F=±1%

6. RATED VOLTAGE CODE

R=4V O=16V B=50V E=250V I=1000V
Q=6.3V A=25V C=100V G=500V J=2000V
P=10V L=35V D=200V H=630V K=3000V

7. THICKNESS CODE

3 = 0.30mm A = 0.65mm F = 1.25mm L = 3.20mm S = 1.35mm
5 = 0.50mm C = 0.85mm H = 1.60mm M = 1.15mm U = 1.80mm
8 = 0.80mm D = 1.00mm I = 2.00mm P = 1.15mm V = 2.50mm
9 = 0.90mm E = 1.10mm J = 2.50mm Q = 1.25mm Y = 1.25mm

8. INNER ELECTRODE / TERMINATION / PLATING CODE

A= Normal Product Pd / Ag / Ni barrier / Sn 100%
N= Normal Product Ni / Cu / Ni barrier / Sn 100%
G= Normal Product Cu / Cu / Ni barrier / Sn 100%
L= Low profile Ni / Cu / Ni barrier / Sn 100%

9. PRODUCT CODE

A= Array(2-element) L= LICC
B= Array(4-element) N= Normal
P= Automotive C= Low ESR (Please refer to p. 35 for application.)

Code	*Size tolerance		
	0402(1005)	0603(1608)	0805(2012)
S	±0.07	±0.07	
Q	±0.1	±0.15	±0.15
R	±0.15	±0.2	±0.2

10. SPECIAL CODE

N= Reserved for future use

11. PACKAGING CODE

B= Bulk O= Cardboard Tape, 10" Reel E= Embossed Type, 7" Reel
P= Bulk Case D= Cardboard Tape, 13" Reel(10,000ea) F= Embossed Type, 13" Reel
C= Cardboard Tape, 7" Reel L= Cardboard Tape, 13" Reel(15,000ea) S= Embossed Type, 10" Reel

Class I (Temperature Compensation)

Symbol	EIA Code	Operation Temperature Range(°C)	Temperature Coefficient Range(ppm/°C)
C	COG	-55 ~ +125	0 ±30
P	P2H	-55 ~ +125	-150 ±60
R	R2H	-55 ~ +125	-220 ±60
S	S2H	-55 ~ +125	-330 ±60
T	T2H	-55 ~ +125	-470 ±60
U	U2J	-55 ~ +125	-750 ±120
L	S2L	-55 ~ +125	-1000 ~ +350

Class II (High Dielectric Constant)

Symbol	EIA Code	Operation Temperature Range(°C)	Capacitance Change(ΔC %)
A	X5R	-55 ~ +85	±15
B	X7R	-55 ~ +125	±15
X	X6S	-55 ~ +105	±22
F	Y5V	-30 ~ +85	-82 ~ +22
Y	X7S	-55 ~ +125	±22

**

Series	TC	Capacitance Step											
		1.0			2.2			4.7					
E-3	Y5V	1.0			2.2			4.7					
E-6	X5R X7R X6S	1.0	1.5	2.2	3.3	4.7	6.8						
E-12	COG TC series	1.0	1.2	1.5	1.8	2.2	2.7	3.3	3.9	4.7	5.6	6.8	8.2

Size	Code	Thickness(mm)	Spec(mm)	Size	Code	Thickness(mm)	Spec(mm)
0201(0603)	3	0.30	±0.03	1210(3225)	H	1.60	±0.20
0402(1005)	5	0.50	±0.05		U	1.80	±0.20
0603(1608)	5	0.50	±0.05		I	2.00	±0.20
	8	0.80	±0.10		J	2.50	±0.20
0805(2012)	A	0.65	±0.10	V	2.50	±0.30	
	C	0.85	±0.10	1808(4520)	F	1.25	±0.20
	D	1.00	±0.15		H	1.60	±0.20
	F	1.25	±0.10		I	2.00	±0.20
	Q	1.25	±0.15	1812(4532)	F	1.25	±0.20
Y	1.25	±0.2	H		1.60	±0.20	
1206(3216)	C	0.85	±0.15	1812(4532)	I	2.00	±0.20
	D	1.00	±0.15		J	2.50	±0.20
	E	1.10	±0.10		L	3.20	±0.30
	P	1.15	±0.10	2220(5750)	F	1.25	±0.20
	F	1.25	±0.15		H	1.60	±0.20
	H	1.60	±0.20		I	2.00	±0.20
1210(3225)	C	0.85	±0.10	2220(5750)	J	2.50	±0.20
	9	0.90	±0.10		L	3.20	±0.30
	E	1.10	±0.10				
	M	1.15	±0.10				
	F	1.25	±0.20				
S	1.35	±0.15					

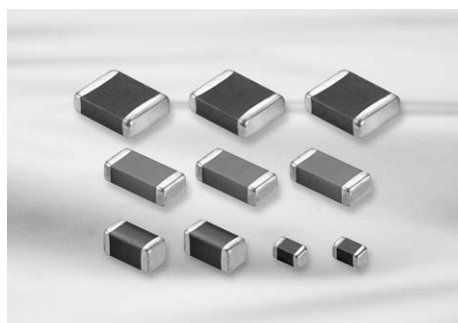

Feature

- Wide selection of size : from 0402 to 2220
- Highly reliable tolerance and high speed automatic chip placement on PCBs
- Wide capacitance range
- Wide temperature compensation and voltage range : from COG to Y5V and from 6.3V to 50V
- Highly reliable performance
- Highly resistant termination metal
- Tape & reel for surface mount assembly

Application

- HHP, DSC, DVC, LCD, TV, Car Navigation, Memory Module, PDA, Game Machine
- Tuner (Product code C is suitable.)

Structure and Dimensions

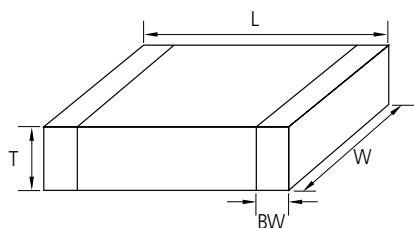

Size Code	EIA Code	Dimension(mm)				
		L	W	T	Thickness Code	BW
05	0402	1.00±0.05	0.50±0.05	0.50±0.05	5	0.2+0.15/-0.1
10	0603	1.60±0.10	0.80±0.10	0.50±0.05	5	0.30±0.20
				0.80±0.10	8	
21	0805	2.00±0.10	1.25±0.10	0.85±0.10	C	0.5+0.2/-0.3
				1.25±0.10	F	
				1.25±0.15	Q	
31	1206	3.20±0.20	1.60±0.20	0.60±0.10	6	0.50+0.30
				0.85±0.10	C	
				0.15±0.10	P	
32	1210	3.20±0.30	2.50±0.20	0.85±0.10	C	0.60±0.30
				0.90±0.10	9	
				1.60±0.20	H	
				1.80±0.20	U	
				2.00±0.20	I	
42	1808	4.50±0.40	2.00±0.20	2.50±0.30	v	0.80±0.30
				2.50±0.30	L	
43	1812	4.50±0.40	3.20±0.30	3.20±0.30	L	0.80±0.30
55	2220	5.70±0.40	5.00±0.40	3.20±0.30	L	1.00±0.30

- Pd MLCC (12th code in part number of pd MLCC = A)
 - Class I type
 - Capacitance < 10pF (Class I. 0402, 0603, 0805 case size)
 - Capacitance < 18pF (Class I. 1206 case size)
 - * Except the capacitance range mentioned as above, All other the capacitance range is using Ni inner electrode for Class I, Class II type(12th code in part number of Ni MLCC = N)

Capacitance Table (General Capacitors)

Size	0402(05)	0603(10)	0805(21)	1206(31)			1210(32)	1812(43)		2220(55)
	COG(C)									
Rated V	50(B)	50(B)	50(B)	25(A)	50(B)	50(B)	25(A)	50(B)	50(B)	
Capacitance -pF- (part numbering code) and thickness -mm-										
0.2(0R2)										
0.5(0R5)										
1(010)										
10(100)										
12(120)										
18(180)										
22(220)										
33(330)										
39(390)										
47(470)	0.5(5)									
56(560)										
100(101)										
150(151)										
180(181)										
220(221)										
270(271)										
330(331)										
390(391)										
470(471)										
560(561)			0.65(A)							
680(681)										
820(821)										
1000(102)		0.8(8)								
1200(122)										
1500(152)										
1800(182)										
2200(222)										
2700(272)										
3300(332)										
3900(392)										
4700(472)										
5600(562)					1.25(F)					
6800(682)										
8200(822)										
10000(103)						1.25(F)				
12000(123)										
15000(153)										
18000(183)										
22000(223)										
27000(273)										
33000(333)										
39000(393)										
43000(433)						1.6(H)				
47000(473)										
56000(563)										
68000(683)										
100000(104)									1.6(H)	
120000(124)										2.5(J)

■:X7R(B) ■:X5R(A) ■:Y5V(F) ■:COG(C) ■:X6S(X)

Capacitance Table (General Capacitors)

Size	0402(05)			0603(10)					0805(21)				
	U2J(U)/S2L(L)	T2H(T)	R2H(R)	U2J(U)/S2L(L)	T2H(T)	R2H(R)	S2H(S)	P2H(P)	U2J(U)/S2L(L)	T2H(T)	R2H(R)	S2H(S)	P2H(P)
Rated V	50(B)												
Capacitance -pF- (part numbering code) and thickness -mm-													
0.5(0R5)													
1(010)													
10(100)													
12(120)													
15(150)													
18(180)													
22(220)													
27(270)													
33(330)	0.5(5)	0.5(5)	0.5(5)										
39(390)													
47(470)							0.8(8)	0.8(8)					
56(560)													0.65(A)
68(680)													
82(820)													
100(101)													
120(121)													
150(151)													
180(181)													
220(221)													
270(271)													
330(331)												0.65(A)	
390(391)												0.65(A)	
470(471)												0.65(A)	
560(561)												0.65(A)	
680(681)													
820(821)												0.85(C)	0.85(C)
1000(102)												0.85(C)	0.85(C)
1200(122)												0.85(C)	0.85(C)
1500(152)												0.85(C)	0.85(C)

:X7R(B) :X5R(A) :Y5V(F) :C0G(C) :X6S(X)

Capacitance Table (General Capacitors)

Size	0402(05)					0603(10)				
	X7R(B) / X5R(A)					X7R(B) / X5R(A)				
Rated V	6.3(Q)	10(P)	16(O)	25(A)	50(B)	6.3(Q)	10(P)	16(O)	25(A)	50(B)
Capacitance -nF- (part numbering code) and thickness -mm-										
0.10(101)										
0.15(151)										
0.22(221)										
0.33(331)										
0.47(471)										
0.68(681)										
1.0(102)					0.5(5)					
1.5(152)										
2.2(222)										
3.3(332)										0.8(8)
4.7(472)										
6.8(682)										
10(103)										
15(153)										
22(223)					0.5(5)					
33(333)										
47(473)										
68(683)										
100(104)										
150(154)										
220(224)										
330(334)										
470(474)										
680(684)										
1000(105)										
1500(155)										
2200(225)										
3300(335)										
4700(475)										
10000(106)										
22000(226)										

:X7R(B) :X5R(A) :Y5V(F) :C0G(C) :X6S(X)

Capacitance Table (General Capacitors)

Size	0805(21)					
TC	X7R(B) / X5R(A)					
Rated V	4(R)	6.3(Q)	10(P)	16(O)	25(A)	50(B)
Capacitance -nF- (part numbering code) and thickness -mm-						
0.15(151)						
0.22(221)						
0.33(331)						
0.47(471)						
0.68(681)						
1.0(102)						
1.5(152)						
2.2(222)						0.65 (A)
3.3(332)						
4.7(472)						
6.8(682)						
10(103)						
15(153)						
22(223)						
33(333)						
47(473)					0.65 (A)	
68(683)					0.85 (C)	0.85 (C)
100(104)				0.65 (A)	0.85 (C)	
150(154)				0.65 (A)	0.85 (C)	
220(224)			0.65 (A)			
330(334)			0.85 (C)	0.85 (C)		
390(394)			0.85 (C)		1.25 (F)	
470(474)			0.85 (C)		1.25 (F)	
680(684)			1.25 (F)	1.25 (F)	0.6 (6)	
1000(105)			1.25 (F)	1.25 (F)	0.85 (C)	
1500(155)			1.25 (F)		0.85 (C)	
2200(225)			1.25 (F)		0.85 (C)	
3300(335)		1.25 (F)				
4700(475)		1.25 (Q)				
6800(685)		1.25 (Q)	0.85 (C)			
10000(106)	0.85 (C)	1.25 (Q)	0.85 (C)	1.25 (Y)	1.25 (Y)	1.25 (Y)
15000(156)	0.85 (C)	1.25 (Q)	0.85 (C)			
22000(226)	0.85 (C)	1.25 (Q)	0.85 (C)			
47000(476)	1.25 (Y)	1.25 (Y)				

Capacitance Table (General Capacitors)

Size	1206(31)					1210(32)				
TC	X7R(B) / X5R(A)									
Rated V	6.3(Q)	10(P)	16(O)	25(A)	50(B)	6.3(Q)	10(P)	16(O)	25(A)	50(B)
Capacitance -nF- (part numbering code) and thickness -mm-										
1.0(102)										
1.5(152)										
2.2(222)										
3.3(332)										
4.7(472)										
6.8(682)										
10(103)										
15(153)										
22(222)										
33(333)										
47(473)										
68(683)										
100(104)										
150(154)					0.85 (C)					
220(224)				0.85 (C)	1.25 (F)					
330(334)				0.85 (C)	1.25 (F)					
470(474)			0.85 (C)	1.25 (F)	1.6 (H)					1.25 (F)
680(684)			0.85 (C)	1.25 (F)	1.6 (H)					1.6 (H)
1000(105)		0.85 (C)	1.25 (F)	1.6 (H)	1.6 (H)				1.25 (F)	1.6 (H)
1500(155)		1.25 (F)	1.6 (H)	1.6 (H)	1.6 (H)				2.0 (I)	2.0 (I)
2200(225)		1.25 (F)	1.6 (H)	1.6 (H)	1.6 (H)			1.25 (F)	2.0 (I)	2.5 (J)
3300(335)		1.6 (H)	1.6 (H)	1.6 (H)	1.6 (H)			1.6 (H)	2.5 (J)	1.8 (U)
4700(475)		1.6 (H)	1.6 (H)	1.6 (H)	1.6 (H)			2.0 (I)	2.5 (J)	1.8 (U)
6800(685)	1.6 (H)	0.85 (C)	1.6 (H)	1.6 (H)	1.6 (H)		2.0 (I)	2.5 (J)	0.85 (C)	0.9 (9)
10000(106)	1.6 (H)	0.85 (C)	1.6 (H)	1.6 (H)	1.6 (H)	2.5 (J)	2.5 (J)	2.5 (J)	2.5 (J)	
22000(226)		0.85 (C)	1.6 (H)	1.6 (H)	1.6 (H)	2.5 (J)	2.5 (J)	2.5 (J)	2.5 (J)	
33000(336)	1.6 (H)					2.5 (J)				
47000(476)	1.6 (H)					2.5 (J)				
68000(686)						2.5 (V)				
100000(107)										

Legend: :X7R(B) :X5R(A) :Y5V(F) :COG(C) :X6S(X)

Capacitance Table (General Capacitors)

Size	1812(43)					2220(55)		
TC	X7R(B) / X5R(A)							
Rated V	6.3(Q)	10(P)	16(O)	25(A)	50(B)	6.3(Q)	10(P)	25(A)
Capacitance -nF- (part numbering code) and thickness -mm-								
10(103)					1.25 (F)			
1000(105)								
1500(155)								
2200(225)								
3300(335)								
4700(475)				2.5 (J)				
6800(685)								2.5 (J)
10000(106)				3.2 (L)				
15000(156)								
22000(226)		2.5 (J)						
33000(336)							2.5 (J)	
47000(476)	2.5 (J)							
100000(107)	3.2 (L)					2.5 (J)		

Capacitance Table (General Capacitors)

Size	0805(21)				1206(31)			
TC	Y5V(F)							
Rated V	10(P)	16(O)	25(A)	50(B)	10(P)	16(O)	25(A)	50(B)
Capacitance -nF- (part numbering code) and thickness -mm-								
2.2(222)								
4.7(472)								
10(103)				0.65 (A)				
22(223)								
47(473)								
100(104)								
220(224)			0.65 (A)					0.85 (C)
470(474)		0.65 (A)	0.85 (C)	1.25 (F)				
1000(105)		0.85 (C)					0.85 (C)	1.25 (F)
2200(225)		1.25 (F)	1.25 (F)			0.85 (C)	1.25 (F)	
4700(475)						1.25 (F)		
10000(106)	1.25 (F)					1.6 (H)		
22000(226)					1.6 (H)			

Size	0402(05)					0603(10)			
TC	Y5V(F)								
Rated V	6.3(Q)	10(P)	16(O)	25(A)	50(B)	6.3(Q)	10(P)	16(O)	50(B)
Capacitance -nF- (part numbering code) and thickness -mm-									
2.2(222)									
4.7(472)					0.50 (5)				
10(103)									
15(153)									
22(223)				0.50 (5)					
47(473)			0.50 (5)						0.80 (8)
100(104)									
220(224)									
470(474)		0.50 (5)							
1000(105)	0.50 (5)							0.80 (8)	
2200(225)							0.80 (8)		
4700(475)						0.80 (8)			

Legend: :X7R(B) :X5R(A) :Y5V(F) :COG(C) :X6S(X)

Size	1210(32)			1812(43)		2220(55)
TC	Y5V(F)					
Rated V	10(P)	25(A)	35(L)	16(O)	50(B)	10(P)
Capacitance -nF- (part numbering code) and thickness -mm-						
10(103)						
22(223)						
47(473)						
100(104)						
220(224)						
470(474)						
1000(105)						
2200(225)						
4700(475)		1.6 (H)	1.6 (H)			
10000(106)					2.5 (J)	
22000(226)	2.5 (J)			2.0 (I)		
47000(476)						
100000(107)						2.5 (J)

Legend: :X7R(B) :X5R(A) :Y5V(F) :COG(C) :X6S(X)

Product Line UP (General Capacitors)

Part Number	Size L×W (1.0×0.5mm)							Capacitance (pF)	Capacitance Tolerance	Rated Voltage (Vdc)	Thickness Max. (mm)
	C	P	R	S	T	U	L				
	COG	P2H	R2H	S2H	T2H	U2J	S2L				
CL05○0R2CB5ANN □	●				●	●		0.20	±0.25pF	50	0.55
CL05○0R5CB5ANN □	●				●	●		0.50	±0.25pF	50	0.55
CL05○0R8CB5ANN □	●				●	●		0.80	±0.25pF	50	0.55
CL05○0R82CB5ANN □	●				●	●		0.82	±0.25pF	50	0.55
CL05○0R9CB5ANN □	●				●	●		0.90	±0.25pF	50	0.55
CL05○010CB5ANN □	●				●	●		1.00	±0.25pF	50	0.55
CL05○01R2CB5ANN □	●				●	●		1.20	±0.25pF	50	0.55
CL05○01R5CB5ANN □	●				●	●		1.50	±0.25pF	50	0.55
CL05○01R8CB5ANN □	●				●	●		1.80	±0.25pF	50	0.55
CL05○020CB5ANN □	●				●	●		2.00	±0.25pF	50	0.55
CL05○02R2CB5ANN □	●				●	●		2.20	±0.25pF	50	0.55
CL05○02R7CB5ANN □	●				●	●		2.70	±0.25pF	50	0.55
CL05○030CB5ANN □	●				●	●		3.00	±0.25pF	50	0.55
CL05○03R3CB5ANN □	●				●	●		3.30	±0.25pF	50	0.55
CL05○03R9CB5ANN □	●				●	●		3.90	±0.25pF	50	0.55
CL05○040CB5ANN □	●				●	●		4.00	±0.25pF	50	0.55
CL05○04R7CB5ANN □	●				●	●		4.70	±0.25pF	50	0.55
CL05○050DB5ANN □	●				●	●		5.00	±0.5pF	50	0.55
CL05○05R6DB5ANN □	●				●	●		5.60	±0.5pF	50	0.55
CL05○060DB5ANN □	●				●	●		6.00	±0.5pF	50	0.55
CL05○06R8DB5ANN □	●				●	●		6.80	±0.5pF	50	0.55
CL05○070DB5ANN □	●				●	●		7.00	±0.5pF	50	0.55
CL05○080DB5ANN □	●				●	●		8.00	±0.5pF	50	0.55
CL05○08R2DB5ANN □	●				●	●		8.20	±0.5pF	50	0.55
CL05○090DB5ANN □	●				●	●		9.00	±0.5pF	50	0.55
CL05○100JB5NNN □	●							10	±5%	50	0.55
CL05○120JB5NNN □	●							12	±5%	50	0.55
CL05○120JB5ANN □					●	●		12	±5%	50	0.55
CL05○150JB5NNN □	●							15	±5%	50	0.55
CL05○180JB5NNN □	●							18	±5%	50	0.55
CL05○220JB5NNN □	●							22	±5%	50	0.55
CL05○270JB5NNN □	●							27	±5%	50	0.55
CL05○270JB5ANN □					●	●		27	±5%	50	0.55
CL05○330JB5NNN □	●							33	±5%	50	0.55
CL05○330JB5ANN □					●	●		33	±5%	50	0.55

※ ○ mark means temperature characteristic code. The parts with mark ● are available to produce.
 ※ □ mark means packaging code. If you want to learn the code or quantity in detail, please see p 59.

Product Line UP (General Capacitors)

Part Number	Size L×W (1.0×0.5mm)							Capacitance (pF)	Capacitance Tolerance	Rated Voltage (Vdc)	Thickness Max. (mm)
	C	P	R	S	T	U	L				
	COG	P2H	R2H	S2H	T2H	U2J	S2L				
CL05○390JB5NNN □	●							39	±5%	50	0.55
CL05○390JB5ANN □					●	●		39	±5%	50	0.55
CL05○470JB5NNN □	●							47	±5%	50	0.55
CL05○470JB5ANN □					●	●		47	±5%	50	0.55
CL05○560JB5NNN □	●							56	±5%	50	0.55
CL05○560JB5ANN □					●	●		56	±5%	50	0.55
CL05○680JB5NNN □	●							68	±5%	50	0.55
CL05○680JB5ANN □					●	●		68	±5%	50	0.55
CL05○820JB5NNN □	●							82	±5%	50	0.55
CL05○820JB5ANN □						●		82	±5%	50	0.55
CL05○101JB5NNN □	●							100	±5%	50	0.55
CL05○101JB5ANN □						●		100	±5%	50	0.55
CL05○121JB5NNN □	●							120	±5%	50	0.55
CL05○151JB5NNN □	●							150	±5%	50	0.55
CL05○151JB5ANN □						●		150	±5%	50	0.55
CL05○181JB5NNN □	●							180	±5%	50	0.55
CL05○221JB5NNN □	●							220	±5%	50	0.55
CL05○271JB5NNN □	●							270	±5%	50	0.55
CL05○331JB5NNN □	●							330	±5%	50	0.55
CL05○471JB5NNN □	●							470	±5%	50	0.55

Part Number	Size L×W (1.6×0.8mm)							Capacitance (pF)	Capacitance Tolerance	Rated Voltage (Vdc)	Thickness Max. (mm)
	C	P	R	S	T	U	L				
	COG	P2H	R2H	S2H	T2H	U2J	S2L				
CL10○0R2CB8ANN □	●		●	●	●	●	●	0.20	±0.25pF	50	0.90
CL10○0R3CB8ANN □	●		●	●	●	●	●	0.30	±0.25pF	50	0.90
CL10○0R4CB8ANN □	●		●	●	●	●	●	0.40	±0.25pF	50	0.90
CL10○0R47CB8ANN □	●		●	●	●	●	●	0.47	±0.25pF	50	0.90
CL10○0R5CB8ANN □	●		●	●	●	●	●	0.50	±0.25pF	50	0.90
CL10○0R56CB8ANN □	●		●	●	●	●	●	0.56	±0.25pF	50	0.90
CL10○0R68CB8ANN □	●		●	●	●	●	●	0.68	±0.25pF	50	0.90
CL10○0R7CB8ANN □	●		●	●	●	●	●	0.70	±0.25pF	50	0.90
CL10○0R8CB8ANN □	●		●	●	●	●	●	0.80	±0.25pF	50	0.90

※ ○ mark means temperature characteristic code. The parts with mark ● are available to produce.
 ※ □ mark means packaging code. If you want to learn the code or quantity in detail, please see p 59.

Product Line UP (General Capacitors)

Part Number	Size L×W (1.6×0.8mm)							Capacitance (pF)	Capacitance Tolerance	Rated Voltage (Vdc)	Thickness Max. (mm)
	C	P	R	S	T	U	L				
	COG	P2H	R2H	S2H	T2H	U2J	S2L				
CL10○R82CB8ANN □	●		●	●	●	●	●	0.82	±0.25pF	50	0.90
CL10○010CB8ANN □	●		●	●	●	●	●	1.00	±0.25pF	50	0.90
CL10○1R2CB8ANN □	●		●	●	●	●	●	1.20	±0.25pF	50	0.90
CL10○1R5CB8ANN □	●		●	●	●	●	●	1.50	±0.25pF	50	0.90
CL10○1R8CB8ANN □	●		●	●	●	●	●	1.80	±0.25pF	50	0.90
CL10○020CB8ANN □	●		●	●	●	●	●	2.00	±0.25pF	50	0.90
CL10○2R2CB8ANN □	●		●	●	●	●	●	2.20	±0.25pF	50	0.90
CL10○2R7CB8ANN □	●		●	●	●	●	●	2.70	±0.25pF	50	0.90
CL10○030CB8ANN □	●		●	●	●	●	●	3.00	±0.25pF	50	0.90
CL10○3R3CB8ANN □	●		●	●	●	●	●	3.30	±0.25pF	50	0.90
CL10○3R9CB8ANN □	●		●	●	●	●	●	3.90	±0.25pF	50	0.90
CL10○040CB8ANN □	●		●	●	●	●	●	4.00	±0.25pF	50	0.90
CL10○4R7CB8ANN □	●		●	●	●	●	●	4.70	±0.25pF	50	0.90
CL10○050DB8ANN □	●		●	●	●	●	●	5.00	±0.5pF	50	0.90
CL10○5R6DB8ANN □	●		●	●	●	●	●	5.60	±0.5pF	50	0.90
CL10○060DB8ANN □	●		●	●	●	●	●	6.00	±0.5pF	50	0.90
CL10○6R8DB8ANN □	●		●	●	●	●	●	6.80	±0.5pF	50	0.90
CL10○070DB8ANN □	●		●	●	●	●	●	7.00	±0.5pF	50	0.90
CL10○080DB8ANN □	●		●	●	●	●	●	8.00	±0.5pF	50	0.90
CL10○8R2DB8ANN □	●		●	●	●	●	●	8.20	±0.5pF	50	0.90
CL10○090DB8ANN □	●		●	●	●	●	●	9.00	±0.5pF	50	0.90
CL10○100JB8NNN □	●							10	±5%	50	0.90
CL10○100JB8ANN □			●	●	●	●	●	10	±5%	50	0.90
CL10○120JB8NNN □	●							12	±5%	50	0.90
CL10○120JB8ANN □			●	●	●	●	●	12	±5%	50	0.90
CL10○150JB8NNN □	●							15	±5%	50	0.90
CL10○150JB8ANN □			●	●	●	●	●	15	±5%	50	0.90
CL10○180JB8NNN □	●							18	±5%	50	0.90
CL10○180JB8ANN □			●	●	●	●	●	18	±5%	50	0.90
CL10○220JB8NNN □	●							22	±5%	50	0.90
CL10○220JB8ANN □			●	●	●	●	●	22	±5%	50	0.90
CL10○270JB8NNN □	●							27	±5%	50	0.90
CL10○270JB8ANN □			●		●	●	●	27	±5%	50	0.90
CL10○330JB8NNN □	●							33	±5%	50	0.90
CL10○330JB8ANN □			●		●	●	●	33	±5%	50	0.90

※ ○ mark means temperature characteristic code. The parts with mark ● are available to produce.
 ※ □ mark means packaging code. If you want to learn the code or quantity in detail, please see p 59.

Product Line UP (General Capacitors)

Part Number	Size L×W (1.6×0.8mm)							Capacitance (pF)	Capacitance Tolerance	Rated Voltage (Vdc)	Thickness Max. (mm)
	C	P	R	S	T	U	L				
	COG	P2H	R2H	S2H	T2H	U2J	S2L				
CL10○390JB8NNN □	●							39	±5%	50	0.90
CL10○390JB8ANN □			●		●	●	●	39	±5%	50	0.90
CL10○470JB8NNN □	●							47	±5%	50	0.90
CL10○470JB8ANN □			●		●	●	●	47	±5%	50	0.90
CL10○560JB8NNN □	●							56	±5%	50	0.90
CL10○560JB8ANN □			●		●	●		56	±5%	50	0.90
CL10○680JB8NNN □	●							68	±5%	50	0.90
CL10○680JB8ANN □			●		●	●		68	±5%	50	0.90
CL10○820JB8NNN □	●							82	±5%	50	0.90
CL10○820JB8ANN □			●		●	●		82	±5%	50	0.90
CL10○101JB8NNN □	●							100	±5%	50	0.90
CL10○101JB8ANN □			●		●	●		100	±5%	50	0.90
CL10○121JB8NNN □	●							120	±5%	50	0.90
CL10○121JB8ANN □			●		●	●		120	±5%	50	0.90
CL10○151JB8NNN □	●							150	±5%	50	0.90
CL10○151JB8ANN □			●		●	●		150	±5%	50	0.90
CL10○181JB8NNN □	●							180	±5%	50	0.90
CL10○181JB8ANN □			●		●	●		180	±5%	50	0.90
CL10○221JB8NNN □	●							220	±5%	50	0.90
CL10○221JB8ANN □					●	●		220	±5%	50	0.90
CL10○271JB8NNN □	●							270	±5%	50	0.90
CL10○271JB8ANN □					●	●		270	±5%	50	0.90
CL10○331JB8NNN □	●							330	±5%	50	0.90
CL10○331JB8ANN □					●	●		330	±5%	50	0.90
CL10○391JB8NNN □	●							390	±5%	50	0.90
CL10○471JB8NNN □	●							470	±5%	50	0.90
CL10○471JB8ANN □						●		470	±5%	50	0.90
CL10○561JB8NNN □	●							560	±5%	50	0.90
CL10○681JB8NNN □	●							680	±5%	50	0.90
CL10○681JB8ANN □						●		680	±5%	50	0.90
CL10○821JB8NNN □	●							820	±5%	50	0.90
CL10○102JB8NNN □	●							1000	±5%	50	0.90
CL10○122JB8NNN □	●							1200	±5%	50	0.90
CL10○222JB8NNN □	●							2200	±5%	50	0.90
CL10○332JA8NNN □	●							3300	±5%	25	0.90

※ ○ mark means temperature characteristic code. The parts with mark ● are available to produce.
 ※ □ mark means packaging code. If you want to learn the code or quantity in detail, please see p 59.

Product Line UP (General Capacitors)

Part Number	Size L×W (2.0×1.25mm)							Capacitance (pF)	Capacitance Tolerance	Rated Voltage (Vdc)	Thickness Max. (mm)
	C	P	R	S	T	U	L				
	COG	P2H	R2H	S2H	T2H	U2J	S2L				
CL21○R47CBAANN □	●	●	●	●	●	●	●	0.47	±0.25pF	50	0.75
CL21○0R5CBAANN □	●	●	●	●	●	●	●	0.50	±0.25pF	50	0.75
CL21○R68CBAANN □	●	●	●	●	●	●	●	0.68	±0.25pF	50	0.75
CL21○R82CBAANN □	●	●	●	●	●	●	●	0.82	±0.25pF	50	0.75
CL21○010CBAANN □	●	●	●	●	●	●	●	1.00	±0.25pF	50	0.75
CL21○1R2CBAANN □	●	●	●	●	●	●	●	1.20	±0.25pF	50	0.75
CL21○1R5CBAANN □	●	●	●	●	●	●	●	1.50	±0.25pF	50	0.75
CL21○1R8CBAANN □	●	●	●	●	●	●	●	1.80	±0.25pF	50	0.75
CL21○020CBAANN □	●	●	●	●	●	●	●	2.00	±0.25pF	50	0.75
CL21○2R2CBAANN □	●	●	●	●	●	●	●	2.20	±0.25pF	50	0.75
CL21○2R7CBAANN □	●	●	●	●	●	●	●	2.70	±0.25pF	50	0.75
CL21○030CBAANN □	●	●	●	●	●	●	●	3.00	±0.25pF	50	0.75
CL21○3R3CBAANN □	●	●	●	●	●	●	●	3.30	±0.25pF	50	0.75
CL21○3R9CBAANN □	●	●	●	●	●	●	●	3.90	±0.25pF	50	0.75
CL21○040CBAANN □	●	●	●	●	●	●	●	4.00	±0.25pF	50	0.75
CL21○4R7CBAANN □	●	●	●	●	●	●	●	4.70	±0.25pF	50	0.75
CL21○050DBAANN □	●	●	●	●	●	●	●	5.00	±0.5pF	50	0.75
CL21○5R6DBAANN □	●	●	●	●	●	●	●	5.60	±0.5pF	50	0.75
CL21○060DBAANN □	●	●	●	●	●	●	●	6.00	±0.5pF	50	0.75
CL21○6R8DBAANN □	●	●	●	●	●	●	●	6.80	±0.5pF	50	0.75
CL21○070DBAANN □	●	●	●	●	●	●	●	7.00	±0.5pF	50	0.75
CL21○080DBAANN □	●	●	●	●	●	●	●	8.00	±0.5pF	50	0.75
CL21○8R2DBAANN □	●	●	●	●	●	●	●	8.20	±0.5pF	50	0.75
CL21○090DBAANN □	●	●	●	●	●	●	●	9.00	±0.5pF	50	0.75
CL21○100JBANN □	●							10	±5%	50	0.75
CL21○100JBAANN □			●	●	●	●	●	10	±5%	50	0.75
CL21○120JBANN □	●							12	±5%	50	0.75
CL21○120JBAANN □			●	●	●	●	●	12	±5%	50	0.75
CL21○150JBANN □	●							15	±5%	50	0.75
CL21○180JBANN □	●							18	±5%	50	0.75
CL21○220JBANN □	●							22	±5%	50	0.75
CL21○270JBANN □	●							27	±5%	50	0.75
CL21○330JBANN □	●							33	±5%	50	0.75
CL21○390JBANN □	●							39	±5%	50	0.75
CL21○470JBANN □	●							47	±5%	50	0.75

※ ○ mark means temperature characteristic code. The parts with mark ● are available to produce.
 ※ □ mark means packaging code. If you want to learn the code or quantity in detail, please see p 59.

Product Line UP (General Capacitors)

Part Number	Size L×W (2.0×1.25mm)							Capacitance (pF)	Capacitance Tolerance	Rated Voltage (Vdc)	Thickness Max. (mm)
	C	P	R	S	T	U	L				
	COG	P2H	R2H	S2H	T2H	U2J	S2L				
CL21○560JBANN □	●							56	±5%	50	0.75
CL21○680JBANN □	●							68	±5%	50	0.75
CL21○820JBANN □	●							82	±5%	50	0.75
CL21○101JBANN □	●							100	±5%	50	0.75
CL21○101JBAANN □			●	●	●	●	●	100	±5%	50	0.75
CL21○121JBANN □	●							120	±5%	50	0.75
CL21○151JBANN □	●							150	±5%	50	0.75
CL21○181JBANN □	●							180	±5%	50	0.75
CL21○221JBANN □	●							220	±5%	50	0.75
CL21○271JBANN □	●							270	±5%	50	0.75
CL21○331JBANN □	●							330	±5%	50	0.75
CL21○331JBAANN □			●	●	●	●	●	330	±5%	50	0.75
CL21○391JBANN □	●							390	±5%	50	0.75
CL21○471JBANN □	●							470	±5%	50	0.75
CL21○471JBAANN □			●	●	●	●	●	470	±5%	50	0.75
CL21○561JBANN □	●							560	±5%	50	0.75
CL21○821JBCNN □	●							820	±5%	50	0.95
CL21○821JBAANN □			●	●	●	●	●	820	±5%	50	0.75
CL21○102JBCNN □	●							1000	±5%	50	0.95
CL21○122JBFNN □	●							1200	±5%	50	1.35
CL21○152JBFNN □	●							1500	±5%	50	1.35
CL21○182JBFNN □	●							1800	±5%	50	1.35
CL21○222JBFNN □	●							2200	±5%	50	1.35
CL21○332JAFNN □	●							3300	±5%	25	1.35
CL21○332JBFNN □	●							3300	±5%	50	1.35
CL21○392JBFNN □	●							3900	±5%	50	1.35
CL21○472JAFNN □	●							4700	±5%	25	1.35
CL21○472JBFNN □	●							4700	±5%	50	1.35
CL21○562JBFNN □	●							5600	±5%	50	1.35
CL21○103JBFNN □	●							10000	±5%	50	1.35

※ ○ mark means temperature characteristic code. The parts with mark ● are available to produce.
 ※ □ mark means packaging code. If you want to learn the code or quantity in detail, please see p 59.

Product Line UP (General Capacitors)

Part Number	Size L×W (3.2×1.6(2.5)mm)							Capacitance (pF)	Capacitance Tolerance	Rated Voltage (Vdc)	Thickness Max. (mm)
	C	P	R	S	T	U	L				
	COG	P2H	R2H	S2H	T2H	U2J	S2L				
CL31○122JBCNNN □	●							1200	±5%	50	0.75
CL31○152JBCNNN □	●							1500	±5%	50	0.75
CL31○182JBCNNN □	●							1800	±5%	50	0.75
CL31○222JBCNNN □	●							2200	±5%	50	0.75
CL31○472JBFNNN □	●							4700	±5%	50	1.35
CL31○562JBHNNN □	●							5600	±5%	50	1.80
CL31○682JBHNNN □	●							6800	±5%	50	1.80
CL31○103JAFNNN □	●							10000	±5%	25	1.35
CL32○103JBFNNN □	●							10000	±5%	50	1.35

Part Number	Size L×W (1.0×0.5mm)			Capacitance	Capacitance Tolerance	Rated Voltage (Vdc)	Thickness Max. (mm)
	A	B	F				
	X5R(EIA)	X7R(EIA)	Y5V(EIA)				
CL05○221KB5NNN □		●		0.22nF	±10%	50	0.55
CL05○331KB5NNN □		●		0.33nF	±10%	50	0.55
CL05○471KB5NNN □		●		0.47nF	±10%	50	0.55
CL05○681KB5NNN □		●		0.68nF	±10%	50	0.55
CL05○102KB5NNN □		●		1.0nF	±10%	50	0.55
CL05○152KB5NNN □		●		1.5nF	±10%	50	0.55
CL05○222KB5NNN □		●		2.2nF	±10%	50	0.55
CL05○332KB5NNN □		●		3.3nF	±10%	50	0.55
CL05○472KB5NNN □		●		4.7nF	±10%	50	0.55
CL05○682KB5NNN □		●		6.8nF	±10%	50	0.55
CL05○103KB5NNN □		●		10nF	±10%	50	0.55
CL05○103ZB5NNN □			●	10nF	+80%~-20%	50	0.55
CL05○153ZB5NNN □			●	15nF	+80%~-20%	50	0.55
CL05○102KA5NNN □		●		1nF	±10%	25	0.55
CL05○222KA5NNN □		●		2.2nF	±10%	25	0.55
CL05○332KA5NNN □		●		3.3nF	±10%	25	0.55
CL05○472KA5NNN □		●		4.7nF	±10%	25	0.55
CL05○682KA5NNN □		●		6.8nF	±10%	25	0.55
CL05○103KA5NNN □		●		10nF	±10%	25	0.55

※ ○ mark means temperature characteristic code. The parts with mark ● are available to produce.
 ※ □ mark means packaging code. If you want to learn the code or quantity in detail, please see p 59.

Product Line UP (General Capacitors)

Part Number	Size L×W (1.0×0.5mm)			Capacitance	Capacitance Tolerance	Rated Voltage (Vdc)	Thickness Max. (mm)
	A	B	F				
	X5R(EIA)	X7R(EIA)	Y5V(EIA)				
CL05○153KA5NNN □		●		15nF	±10%	25	0.55
CL05○223KA5NNN □		●		22nF	±10%	25	0.55
CL05○223ZA5NNN □			●	22nF	+80%~-20%	25	0.55
CL05○333ZA5NNN □			●	33nF	+80%~-20%	25	0.55
CL05○104KA5NNN □	●			100nF	±10%	25	0.55
CL05○102KO5NNN □		●		1.0nF	±10%	16	0.55
CL05○472KO5NNN □		●		4.7nF	±10%	16	0.55
CL05○682KO5NNN □		●	●	6.8nF	±10%	16	0.55
CL05○103KO5NNN □		●		10nF	±10%	16	0.55
CL05○103ZO5NNN □			●	10nF	+80%~-20%	16	0.55
CL05○153KO5NNN □		●		15nF	±10%	16	0.55
CL05○223KO5NNN □		●		22nF	±10%	16	0.55
CL05○223ZO5NNN □			●	22nF	+80%~-20%	16	0.55
CL05○333KO5NNN □		●		33nF	±10%	16	0.55
CL05○473KO5NNN □		●		47nF	±10%	16	0.55
CL05○473ZO5NNN □			●	47nF	+80%~-20%	16	0.55
CL05○683KO5NNN □		●		68nF	±10%	16	0.55
CL05○104KO5NNN □	●	●		100nF	±10%	16	0.55
CL05○104ZO5NNN □			●	100nF	+80%~-20%	16	0.55
CL05○224ZO5NNN □			●	220nF	+80%~-20%	16	0.55
CL05○103KP5NNN □		●		10nF	±10%	10	0.55
CL05○333KP5NNN □		●		33nF	±10%	10	0.55
CL05○473KP5NNN □	●	●		47nF	±10%	10	0.55
CL05○683KP5NNN □		●		68nF	±10%	10	0.55
CL05○104KP5NNN □	●	●		100nF	±10%	10	0.55
CL05○224ZP5NNN □			●	220nF	+80%~-20%	10	0.55
CL05○474ZP5NNN □			●	470nF	+80%~-20%	10	0.55
CL05○104KQ5NNN □	●	●		100nF	±10%	6.3	0.55
CL05○154KQ5NNN □	●			150nF	±10%	6.3	0.55
CL05○474KQ5NNN □			●	470nF	+80%~-20%	6.3	0.55

※ ○ mark means temperature characteristic code. The parts with mark ● are available to produce.
 ※ □ mark means packaging code. If you want to learn the code or quantity in detail, please see p 59.

Product Line UP (General Capacitors)

Part Number	Size L×W (1.6×0.8mm)			Capacitance	Capacitance Tolerance	Rated Voltage (Vdc)	Thickness Max. (mm)
	A	B	F				
	X5R(EIA)	X7R(EIA)	Y5V(EIA)				
CL10○101KB8NNN □		●		0.10nF	±10%	50	0.90
CL10○151KB8NNN □		●		0.15nF	±10%	50	0.90
CL10○221KB8NNN □		●		0.22nF	±10%	50	0.90
CL10○331KB8NNN □		●		0.33nF	±10%	50	0.90
CL10○471KB8NNN □		●		0.47nF	±10%	50	0.90
CL10○681KB8NNN □		●		0.68nF	±10%	50	0.90
CL10○102KB8NNN □		●		1.0nF	±10%	50	0.90
CL10○152KB8NNN □		●		1.5nF	±10%	50	0.90
CL10○222KB8NNN □		●		2.2nF	±10%	50	0.90
CL10○332KB8NNN □		●		3.3nF	±10%	50	0.90
CL10○472KB8NNN □		●		4.7nF	±10%	50	0.90
CL10○682KB8NNN □		●		6.8nF	±10%	50	0.90
CL10○103KB8NNN □		●		10nF	±10%	50	0.90
CL10○103ZB8NNN □			●	10nF	+80%~-20%	50	0.90
CL10○153KB8NNN □		●		15nF	±10%	50	0.90
CL10○223KB8NNN □		●		22nF	±10%	50	0.90
CL10○223ZB8NNN □			●	22nF	+80%~-20%	50	0.90
CL10○333KB8NNN □		●		33nF	±10%	50	0.90
CL10○473KB8NNN □		●		47nF	±10%	50	0.90
CL10○473ZB8NNN □			●	47nF	+80%~-20%	50	0.90
CL10○683KB8NNN □		●		68nF	±10%	50	0.90
CL10○104KB8NNN □		●		100nF	±10%	50	0.90
CL10○104ZB8NNN □			●	100nF	+80%~-20%	50	0.90
CL10○224ZB8NNN □			●	220nF	+80%~-20%	50	0.90
CL10○474ZB8NNN □			●	470nF	+80%~-20%	50	0.90
CL10○102KA8NNN □		●		1.0nF	±10%	25	0.90
CL10○472KA8NNN □		●		4.7nF	±10%	25	0.90
CL10○682KA8NNN □		●		6.8nF	±10%	25	0.90
CL10○103KA8NNN □		●		10nF	±10%	25	0.90
CL10○153KA8NNN □		●		15nF	±10%	25	0.90
CL10○223KA8NNN □		●		22nF	±10%	25	0.90
CL10○223ZA8NNN □			●	22nF	+80%~-20%	25	0.90
CL10○333KA8NNN □		●		33nF	±10%	25	0.90
CL10○473KA8NNN □		●		47nF	±10%	25	0.90
CL10○473ZA8NNN □			●	47nF	+80%~-20%	25	0.90

※ ○ mark means temperature characteristic code. The parts with mark ● are available to produce.
 ※ □ mark means packaging code. If you want to learn the code or quantity in detail, please see p 59.

Product Line UP (General Capacitors)

Part Number	Size L×W (1.6×0.8mm)			Capacitance	Capacitance Tolerance	Rated Voltage (Vdc)	Thickness Max. (mm)
	A	B	F				
	X5R(EIA)	X7R(EIA)	Y5V(EIA)				
CL10○683KA8NNN □		●		68nF	±10%	25	0.90
CL10○104KA8NNN □		●		100nF	±10%	25	0.90
CL10○104ZA8NNN □			●	100nF	+80%~-20%	25	0.90
CL10○224KA8NNN □	●			220nF	±10%	25	0.90
CL10○224ZA8NNN □			●	220nF	+80%~-20%	25	0.90
CL10○334KA8NNN □	●			330nF	±10%	25	0.90
CL10○474ZA8NNN □			●	470nF	+80%~-20%	25	0.90
CL10○105KA8NNN □		●		1.0nF	±10%	25	0.90
CL10○102KO8NNN □		●		1.0nF	±10%	16	0.90
CL10○103KO8NNN □		●		10nF	±10%	16	0.90
CL10○153KO8NNN □		●		15nF	±10%	16	0.90
CL10○223KO8NNN □		●		22nF	±10%	16	0.90
CL10○333KO8NNN □		●		33nF	±10%	16	0.90
CL10○473KO8NNN □		●	●	47nF	±10%	16	0.90
CL10○473ZO8NNN □				47nF	+80%~-20%	16	0.90
CL10○683KO8NNN □		●		68nF	±10%	16	0.90
CL10○104KO8NNN □		●	●	100nF	±10%	16	0.90
CL10○104ZO8NNN □				100nF	+80%~-20%	16	0.90
CL10○154KO8NNN □		●		150nF	±10%	16	0.90
CL10○224KO8NNN □		●		220nF	±10%	16	0.90
CL10○224ZO8NNN □			●	220nF	+80%~-20%	16	0.90
CL10○334KO8NNN □		●		330nF	±10%	16	0.90
CL10○474KO8NNN □		●		470nF	±10%	16	0.90
CL10○474ZO8NNN □			●	470nF	+80%~-20%	16	0.90
CL10○105KO8NNN □		●		1.0μF	±10%	16	0.90
CL10○105ZO8NNN □			●	1.0μF	+80%~-20%	16	0.90
CL10○154KP8NNN □		●		150nF	±10%	10	0.90
CL10○224KP8NNN □	●	●		220nF	±10%	10	0.90
CL10○334KP8NNN □		●		330nF	±10%	10	0.90
CL10○474KP8NNN □		●		470nF	±10%	10	0.90
CL10○474ZP8NNN □			●	470nF	+80%~-20%	10	0.90
CL10○105ZP8NNN □			●	1.0μF	+80%~-20%	10	0.90
CL10○474KQ8NNN □		●		470nF	±10%	6.3	0.90
CL10○684KQ8NNN □		●		680	±10%	6.3	0.90
CL10○105KQ8NNN □		●		1.0μF	±10%	6.3	0.90
CL10○225KQ8NNN □		●		2.2μF	±10%	6.3	0.90

※ ○ mark means temperature characteristic code. The parts with mark ● are available to produce.
 ※ □ mark means packaging code. If you want to learn the code or quantity in detail, please see p 59.

Product Line UP (General Capacitors)

Part Number	Size L × W (2.0 × 1.25mm)			Capacitance	Capacitance Tolerance	Rated Voltage (Vdc)	Thickness Max. (mm)
	A	B	F				
	X5R(EIA)	X7R(EIA)	Y5V(EIA)				
CL21 ○ 151KBANNN □		●		0.15nF	±10%	50	0.75
CL21 ○ 221KBANNN □		●		0.22nF	±10%	50	0.75
CL21 ○ 331KBANNN □		●		0.33nF	±10%	50	0.75
CL21 ○ 471KBANNN □		●		0.47nF	±10%	50	0.75
CL21 ○ 681KBANNN □		●		0.68nF	±10%	50	0.75
CL21 ○ 102KBANNN □		●		1.0nF	±10%	50	0.75
CL21 ○ 152KBANNN □		●		1.5nF	±10%	50	0.75
CL21 ○ 222KBANNN □		●		2.2nF	±10%	50	0.75
CL21 ○ 332KBANNN □		●		3.3nF	±10%	50	0.75
CL21 ○ 332KBCNNN □		●		3.3nF	±10%	50	0.95
CL21 ○ 472KBANNN □		●		4.7nF	±10%	50	0.75
CL21 ○ 682KBANNN □		●		6.8nF	±10%	50	0.75
CL21 ○ 103KBANNN □		●		10nF	±10%	50	0.75
CL21 ○ 103KBCNNN □		●		10nF	±10%	50	0.95
CL21 ○ 103ZBANNN □			●	10nF	+80%~-20%	50	0.75
CL21 ○ 153KBANNN □		●		15nF	±10%	50	0.75
CL21 ○ 223KBANNN □		●		22nF	±10%	50	0.75
CL21 ○ 223ZBANNN □			●	22nF	+80%~-20%	50	0.75
CL21 ○ 333KBANNN □		●		33nF	±10%	50	0.75
CL21 ○ 473ZBANNN □			●	47nF	+80%~-20%	50	0.75
CL21 ○ 683KBCNNN □		●		68nF	±10%	50	0.95
CL21 ○ 104KBCNNN □		●		100nF	±10%	50	0.95
CL21 ○ 104ZBANNN □			●	100nF	+80%~-20%	50	0.75
CL21 ○ 104ZBCNNN □			●	100nF	+80%~-20%	50	0.95
CL21 ○ 154KBFNNN □		●		150nF	±10%	50	1.35
CL21 ○ 224KBFNNN □		●		220nF	±10%	50	1.35
CL21 ○ 224ZBCNNN □			●	220nF	+80%~-20%	50	0.95
CL21 ○ 474ZBFNNN □			●	470nF	+80%~-20%	50	1.35
CL21 ○ 105KBFNNN □		●		1.0μF	±10%	50	1.35
CL21 ○ 105ZBFNNN □			●	1.0μF	+80%~-20%	50	1.35
CL21 ○ 102KAANNN □		●		1.0nF	±10%	25	0.75
CL21 ○ 103KAANNN □		●		10nF	±10%	25	0.75
CL21 ○ 473KAANNN □		●		47nF	±10%	25	0.75
CL21 ○ 683KAANNN □		●		68nF	±10%	25	0.75
CL21 ○ 104KACNNN □		●		100nF	±10%	25	0.95
CL21 ○ 104ZANNN □			●	100nF	+80%~-20%	25	0.75

※ ○ mark means temperature characteristic code. The parts with mark ● are available to produce.
 ※ □ mark means packaging code. If you want to learn the code or quantity in detail, please see p 59.

Product Line UP (General Capacitors)

Part Number	Size L × W (2.0 × 1.25mm)			Capacitance	Capacitance Tolerance	Rated Voltage (Vdc)	Thickness Max. (mm)
	A	B	F				
	X5R(EIA)	X7R(EIA)	Y5V(EIA)				
CL21 ○ 154KAFNNN □		●		150nF	±10%	25	1.35
CL21 ○ 224KAFNNN □		●		220nF	±10%	25	1.35
CL21 ○ 224ZANNN □			●	220nF	+80%~-20%	25	0.75
CL21 ○ 334KAFNNN □		●		330nF	±10%	25	1.35
CL21 ○ 474KAFNNN □		●		470nF	±10%	25	1.35
CL21 ○ 474ZACNNN □			●	470nF	+80%~-20%	25	0.95
CL21 ○ 105KAFNNN □		●		1.0μF	±10%	25	1.35
CL21 ○ 105ZAFNNN □			●	1.0μF	+80%~-20%	25	1.35
CL21 ○ 225ZAFNNN □			●	2.2μF	+80%~-20%	25	1.35
CL21 ○ 153KOANNN □		●		15nF	±10%	16	0.75
CL21 ○ 333KOANNN □		●		33nF	±10%	16	0.75
CL21 ○ 104KOANNN □		●		100nF	±10%	16	0.75
CL21 ○ 104ZOANNN □			●	100nF	+80%~-20%	16	0.75
CL21 ○ 154KOANNN □		●		150nF	±10%	16	0.75
CL21 ○ 224KOCNNN □		●		220nF	±10%	16	0.95
CL21 ○ 224ZOANNN □			●	220nF	+80%~-20%	16	0.75
CL21 ○ 334KOCNNN □		●		330nF	±10%	16	0.95
CL21 ○ 474KOFNNN □		●		470nF	±10%	16	1.35
CL21 ○ 474ZOANNN □			●	470nF	+80%~-20%	16	0.75
CL21 ○ 474ZOCNNN □			●	470nF	+80%~-20%	16	0.95
CL21 ○ 684KOFNNN □		●		680nF	±10%	16	1.35
CL21 ○ 105KOFNNN □		●		1.0μF	±10%	16	1.35
CL21 ○ 105ZOCNNN □			●	1.0μF	+80%~-20%	16	0.95
CL21 ○ 105ZOFNNN □			●	1.0μF	+80%~-20%	16	1.35
CL21 ○ 225ZOFNNN □			●	2.2μF	+80%~-20%	16	1.35
CL21 ○ 475ZOFNNN □			●	4.7μF	+80%~-20%	16	1.35
CL21 ○ 474KPCNNN □		●		470nF	±10%	10	0.95
CL21 ○ 684KPFNNN □		●		680nF	±10%	10	1.35
CL21 ○ 105KPFNNN □		●		1.0μF	±10%	10	1.35
CL21 ○ 225ZPFNNN □			●	2.2μF	+80%~-20%	10	1.35
CL21 ○ 475ZPFNNN □			●	4.7μF	+80%~-20%	10	1.35

※ ○ mark means temperature characteristic code. The parts with mark ● are available to produce.
 ※ □ mark means packaging code. If you want to learn the code or quantity in detail, please see p 59.

Product Line UP (General Capacitors)

Part Number	Size L×W (3.2×1.6mm)			Capacitance	Capacitance Tolerance	Rated Voltage (Vdc)	Thickness Max. (mm)
	A	B	F				
	X5R(EIA)	X7R(EIA)	Y5V(EIA)				
CL31○154KBCNNN □		●		150nF	±10%	50	1.00
CL31○334KBFNNN □		●		330nF	±10%	50	1.40
CL31○474KBHNNN □		●		470nF	±10%	50	1.8
CL31○474ZBCNNN □			●	470nF	+80%~-20%	50	1.00
CL31○684KBHNNN □		●		680nF	±10%	50	1.8
CL31○105KBHNNN □		●		1.0μF	±10%	50	1.8
CL31○105ZBFNNN □			●	1.0μF	+80%~-20%	50	1.40
CL31○225KBHNNN □	●			2.2μF	±10%	50	1.8
CL31○104KACNNN □		●		100nF	±10%	25	1.00
CL31○154KACNNN □		●		150nF	±10%	25	1.00
CL31○224KACNNN □		●		220nF	±10%	25	1.00
CL31○334KACNNN □		●		330nF	±10%	25	1.00
CL31○684KAHNNN □		●		680nF	±10%	25	1.8
CL31○105KAPNNN □		●		1.0μF	±10%	25	1.25
CL31○105KAHNNN □		●		1.0μF	±10%	25	1.8
CL31○105ZACNNN □			●	1.0μF	+80%~-20%	25	1.00
CL31○225KAHNNN □	●	●		2.2μF	±10%	25	1.8
CL31○225ZAFNNN □			●	2.2μF	+80%~-20%	25	1.40
CL31○334KOCNNN □		●		330nF	±10%	16	1.00
CL31○474KOCNNN □		●		470nF	±10%	16	1.00
CL31○684KOCNNN □		●		680nF	±10%	16	1.00
CL31○105ZOCNNN □			●	1.0μF	+80%~-20%	16	1.00
CL31○155KOFNNN □		●		1.5μF	±10%	16	1.40
CL31○225KOHNNN □		●		2.2μF	±10%	16	1.8
CL31○225ZOCNNN □			●	2.2μF	+80%~-20%	16	1.00
CL31○335KOC LNN □	●			3.3μF	±10%	16	1.00
CL31○335KOHNNN □	●	●		3.3μF	±10%	16	1.8
CL31○475ZOENNN □			●	4.7μF	+80%~-20%	16	1.25
CL31○475ZOFNNN □			●	4.7μF	+80%~-20%	16	1.40
CL31○106ZOHNNN □			●	10μF	+80%~-20%	16	1.8
CL31○105KPCNNN □		●		1.0μF	±10%	10	1.00
CL31○225KPENNN □		●		2.2μF	±10%	10	1.25
CL31○475KPHNNN □		●		4.7μF	±10%	10	1.8
CL31○106ZPENNN □			●	10μF	+80%~-20%	10	1.25
CL31○106ZPFNNN □			●	10μF	+80%~-20%	10	1.40
CL31○685KQHNNN □		●		6.8μF	±10%	6.3	1.8
CL31○106KQHNNN □		●		10μF	±10%	6.3	1.8

※○mark means temperature characteristic code. The parts with mark ●are available to produce.
 ※□mark means packaging code. If you want to learn the code or quantity in detail, please see p 59.

Product Line UP (General Capacitors)

Part Number	Size L×W (3.2×2.5mm)			Capacitance	Capacitance Tolerance	Rated Voltage (Vdc)	Thickness Max. (mm)
	A	B	F				
	X5R(EIA)	X7R(EIA)	Y5V(EIA)				
CL32○474KBFNNN □		●		470nF	±10%	50	1.45
CL32○105KBHNNN □		●		1.0μF	±10%	50	1.80
CL32○225KBJNNN □		●		2.2μF	±10%	50	2.70
CL32○475KLULNN □	●			4.7μF	±10%	35	2.00
CL32○106KLULNN □	●			10μF	±10%	35	2.00
CL32○106ZLHNNN □			●	10μF	+80%~-20%	35	1.80
CL32○105KAFNNN □		●		1.0μF	±10%	25	1.45
CL32○225KANNNN □		●		2.2μF	±10%	25	2.20
CL32○475KAULNN □	●			4.7μF	±10%	25	2.00
CL32○475KAI NN N □	●			4.7μF	±10%	25	2.20
CL32○475ZAHNNN □			●	4.7μF	+80%~-20%	25	1.80
CL32○106KA9LNN □	●			10μF	±10%	25	1.00
CL32○106KATLNN □	●			10μF	±10%	25	1.70
CL32○106KAULNN □	●			10μF	±10%	25	2.00
CL32○106KAJNNN □		●		10μF	±10%	25	2.70
CL32○106KAJSNN □		●		10μF	±10%	25	2.70
CL32○106ZAHNNN □			●	10μF	+80%~-20%	25	1.80
CL32○106ZASLNN □			●	10μF	+80%~-20%	25	1.50
CL32○475KOINNN □		●		4.7μF	±10%	16	2.20
CL32○475ZO9LNN □			●	4.7μF	+80%~-20%	16	1.00
CL32○475ZOFNNN □			●	4.7μF	+80%~-20%	16	1.45
CL32○106KOC LNN □	●			10μF	±10%	16	0.95
CL32○106KO9LNN □	●			10μF	±10%	16	1.00
CL32○106KOMLNN □	●			10μF	±10%	16	1.25
CL32○106KOTLNN □	●			10μF	±10%	16	1.70
CL32○106KOJNNN □	●	●		10μF	±10%	16	2.70
CL32○106ZOELNN □			●	10μF	+80%~-20%	16	1.20
CL32○106ZOHNNN □			●	10μF	+80%~-20%	16	1.80
CL32○106ZOMLNN □			●	10μF	+80%~-20%	16	1.25
CL32○106KPI NN N □	●	●		10μF	±10%	10	2.20

Part Number	Size L×W (4.5×3.2mm)			Capacitance	Capacitance Tolerance	Rated Voltage (Vdc)	Thickness Max. (mm)
	A	B	F				
	X5R(EIA)	X7R(EIA)	Y5V(EIA)				
CL43○684KBFNNN □		●		680nF	±10%	50	1.45
CL43○105KBFNNN □		●		1μF	±10%	50	1.45
CL43○106KALNNN □		●		10μF	±10%	25	3.40

Part Number	Size L×W (5.7×5.0mm)			Capacitance	Capacitance Tolerance	Rated Voltage (Vdc)	Thickness Max. (mm)
	A	B	F				
	X5R(EIA)	X7R(EIA)	Y5V(EIA)				
CL55○105KBINNN □		●		1μF	±10%	50	2.20
CL55○476KPJNNN □	●			47μF	±10%	10	2.70
CL55○107KQJNNN □	●			100μF	±10%	6.3	2.70
CL55○107ZPJNNN □			●	100μF	+80%~-20%	10	2.70

※○mark means temperature characteristic code. The parts with mark ●are available to produce.
 ※□mark means packaging code. If you want to learn the code or quantity in detail, please see p 59.

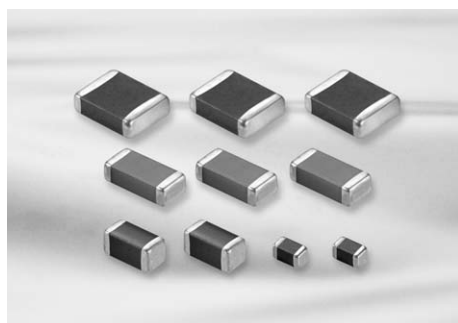

Feature

- Wide selection of size : from 0402 to 1812
- Highly reliable tolerance and high speed automatic chip placement on PCBs
- Wide capacitance range
- Highly reliable performance
- Highly resistant termination metal
- Tape & reel for surface mount assembly

Application

- Desktop PC, Note PC, HHP, DC-DC Converter, DSC
- LCD TV, LCD Monitor

Structure and Dimensions

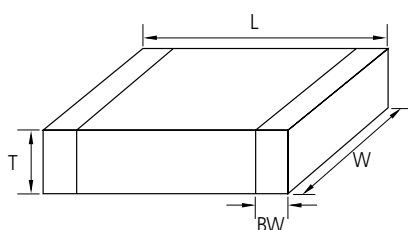

Size Code	EIA Code	Dimension(mm)				
		L	W	T	Thickness Code	BW
05	0402	1.00±0.05	0.50±0.05	0.50±0.05	5	0.2+0.15/-0.1
10	0603	1.60±0.10	0.80±0.10	0.50±0.05	5	0.30±0.20
				0.80±0.10	8	
21	0805	2.00±0.10	1.25±0.10	0.85±0.10	C	0.5+0.2/-0.3
				1.25±0.10	F	
				1.25±0.15	Q	
21	0805	2.00±0.15	1.25±0.15	1.25±0.15	Y	0.5+0.2/-0.3
				1.25±0.20	Y	
				1.25±0.20	Y	
31	1206	3.20±0.20	1.60±0.20	0.60±0.10	6	0.50+0.30
				0.85±0.10	C	
				0.15±0.10	P	
				1.25±0.15	F	
31	1206	3.20±0.15	1.60±0.15	1.60±0.20	H	0.50+0.30
				1.60±0.20	H	
				1.60±0.20	H	
32	1210	3.20±0.30	2.50±0.20	0.85±0.10	C	0.60±0.30
				0.90±0.10	g	
				1.60±0.20	H	
				1.80±0.20	U	
				2.00±0.20	I	
				2.50±0.20	J	
32	1210	3.20±0.40	2.50±0.30	2.50±0.30	v	0.60±0.30
				2.50±0.30	v	
42	1808	4.50±0.40	2.00±0.20	2.00±0.20	I	0.80±0.30
43	1812	4.50±0.40	3.20±0.30	3.20±0.30	L	0.80±0.30
55	2220	5.70±0.40	5.00±0.40	3.20±0.30	L	1.00±0.30

Capacitance Table (Ultra High Capacitors)

Size	0402(05)				0603(10)				
	X5R(A)								
TC	4(R)	6.3(Q)	10(P)	16(O)	4(R)	6.3(Q)	10(P)	16(O)	25(A)
Rated V	Capacitance -nF- (part numbering code) and thickness -mm-								
0.10(101)									
0.15(151)									
0.22(221)									
0.33(331)									
0.47(471)									
0.68(681)									
1.0(102)									
1.5(152)									
2.2(222)									
3.3(332)									
4.7(472)									
6.8(682)									
10(103)									
15(153)									
22(223)									
33(333)									
47(473)									
68(683)									
100(104)									
150(154)									
220(224)									
330(334)									
470(474)									
680(684)									
1000(105)									
1500(155)									
2200(225)									
3300(335)									
4700(475)									
10000(106)									
22000(226)									

Legend: :X7R(B) :X5R(A) :Y5V(F) :C0G(C) :X6S(X)

Ultra High Capacitors

Capacitance Table (Ultra High Capacitors)

Size	0805(21)					1206(31)				1210(32)				1812(43)
TC	X5R(A)													
Rated V	4(R)	6.3(Q)	10(P)	16(O)	25(A)	6.3(Q)	10(P)	16(O)	25(A)	6.3(Q)	10(P)	16(O)	25(A)	6.3(Q)
Capacitance -nF- (part numbering code) and thickness -mm-														
0.15(151)														
0.22(221)														
0.33(331)														
0.47(471)														
0.68(681)														
1.0(102)														
1.5(152)														
2.2(222)														
3.3(332)														
4.7(472)														
6.8(682)														
10(103)														
15(153)														
22(223)														
33(333)														
47(473)														
68(683)														
100(104)														
150(154)														
220(224)														
330(334)														
390(394)														
470(474)														
680(684)														
1000(105)					0.6 (6)									
1500(155)					0.85 (C)									
2200(225)					0.85 (C)									
3300(335)					0.85 (C)									
4700(475)					0.85 (C)									
6800(685)		0.85 (C)		0.85 (C)										
10000(106)		0.85 (C)		1.25 (Y)										
15000(156)					1.6 (H)									
22000(226)	0.85 (C)									2.5 (J)	2.5 (J)	2.5 (J)	2.5 (J)	
47000(476)	1.25 (Y)	1.25 (Y)								2.5 (J)				2.5 (J)
68000(686)										2.5 (V)				
100000(107)														3.2 (L)

Capacitance Table (Ultra High Capacitors)

Size	0402(05)	0603(10)			0805(21)			
TC	X7R(B) / X6S(X)							
Rated V	6.3(Q)	4(R)	6.3(Q)	4(R)	6.3(Q)	10(P)	16(O)	25(A)
Capacitance -nF- (part numbering code) and thickness -mm-								
2.2(222)								
4.7(472)								
10(103)								
22(223)								
47(473)								
100(104)								
220(224)								
470(474)								
1000(105)	0.5 (5)			0.8 (8)				
2200(225)				0.8 (8)		1.25 (F)		1.25 (F)
4700(475)		0.8 (8)		0.8 (8)		1.25 (Q)	0.85 (C)	
10000(106)				0.85 (C)		1.25 (Q)		1.25 (Y)
22000(226)								
47000(476)								
100000(107)								

Size	1206(31)	1210(32)	0402(05)	0603(10)	0805(21)	1206(31)	1210(32)
TC	X7R(B) / X6S(X)			Y5V(F)			
Rated V	6.3(Q)	6.3(O)	25(A)	6.3(Q)	6.3(Q)	10(P)	10(P)
Capacitance -nF- (part numbering code) and thickness -mm-							
2.2(222)							
4.7(472)							
10(103)							
22(223)							
47(473)							
100(104)							
220(224)							
470(474)							
1000(105)					0.50 (5)		
2200(225)						0.80 (5)	
4700(475)					0.80 (5)		
10000(106)	1.6 (H)	1.6 (H)					1.25 (F)
22000(226)							1.6 (H)
47000(476)							2.5 (J)
100000(107)							

Ultra High Capacitors

Product Line UP (Ultra High Capacitors)

Part Number	TC Code	Temperature Characteristics	Size L × W (mm)	Capacitance	Capacitance Tolerance	Rated Voltage (Vdc)	Thickness Max. (mm)
CL05A334KA5NNN □	X5R(EIA)	±15%(-55~+85℃)	1.00 × 0.50	0.33μF	±10%	25	0.55
CL10A474KA8NNN □	X5R(EIA)	±15%(-55~+85℃)	1.60 × 0.80	0.47μF	±10%	25	0.90
CL10A105KA5NNN □	X5R(EIA)	±15%(-55~+85℃)	1.60 × 0.80	1.0μF	±10%	25	0.55
CL21A105KACLNN □	X5R(EIA)	±15%(-55~+85℃)	2.00 × 1.25	1.0μF	±10%	25	0.95
CL21A105KAFNNN □	X5R(EIA)	±15%(-55~+85℃)	2.00 × 1.25	1.0μF	±10%	25	1.35
CL10A225KA5LNN □	X5R(EIA)	±15%(-55~+85℃)	1.60 × 0.80	2.2μF	±10%	25	0.55
CL21A225KACLNN □	X5R(EIA)	±15%(-55~+85℃)	2.00 × 1.25	2.2μF	±10%	25	0.95
CL21A225KAFNNN □	X5R(EIA)	±15%(-55~+85℃)	2.00 × 1.25	2.2μF	±10%	25	1.35
CL21A475KACLRN □	X5R(EIA)	±15%(-55~+85℃)	2.00 × 1.25	4.7μF	±10%	25	0.95
CL31A475KACLNN □	X5R(EIA)	±15%(-55~+85℃)	3.20 × 1.60	4.7μF	±10%	25	0.95
CL31A475KAPLNN □	X5R(EIA)	±15%(-55~+85℃)	3.20 × 1.60	4.7μF	±10%	25	1.25
CL31A475KAHNNN □	X5R(EIA)	±15%(-55~+85℃)	3.20 × 1.60	4.7μF	±10%	25	1.80
CL21A106KAYNNN □	X5R(EIA)	±15%(-55~+85℃)	2.00 × 1.25	10μF	±10%	25	1.45
CL31A106KACLNN □	X5R(EIA)	±15%(-55~+85℃)	3.20 × 1.60	10μF	±10%	25	0.95
CL31A106KAHNNN □	X5R(EIA)	±15%(-55~+85℃)	3.20 × 1.60	10μF	±10%	25	1.80
CL32A226KAJNNN □	X5R(EIA)	±15%(-55~+85℃)	3.20 × 2.50	22μF	±10%	25	2.70
CL10A474KO8NNN □	X5R(EIA)	±15%(-55~+85℃)	1.60 × 0.80	0.47μF	±10%	16	0.90
CL05A105KO5NNN □	X5R(EIA)	±15%(-55~+85℃)	1.00 × 0.50	1.0μF	±10%	16	0.55
CL10A105KO5LNN □	X5R(EIA)	±15%(-55~+85℃)	1.60 × 0.80	1.0μF	±10%	16	0.55
CL10A105KO8NNN □	X5R(EIA)	±15%(-55~+85℃)	1.60 × 0.80	1.0μF	±10%	16	0.90
CL21A105KO6LNN □	X5R(EIA)	±15%(-55~+85℃)	2.00 × 1.25	1.0μF	±10%	16	0.70
CL21A105KOFNNN □	X5R(EIA)	±15%(-55~+85℃)	2.00 × 1.25	1.0μF	±10%	16	1.35
CL10A225KO5LNN □	X5R(EIA)	±15%(-55~+85℃)	1.60 × 0.80	2.2μF	±10%	16	0.55
CL10A225KO8NNN □	X5R(EIA)	±15%(-55~+85℃)	1.60 × 0.80	2.2μF	±10%	16	0.90
CL21A225KOFNNN □	X5R(EIA)	±15%(-55~+85℃)	2.00 × 1.25	2.2μF	±10%	16	1.35
CL10A475KO8NNN □	X5R(EIA)	±15%(-55~+85℃)	1.60 × 0.80	4.7μF	±10%	16	0.90
CL21A475KOFNNN □	X5R(EIA)	±15%(-55~+85℃)	2.00 × 1.25	4.7μF	±10%	16	1.35
CL31A475KACLNN □	X5R(EIA)	±15%(-55~+85℃)	3.20 × 1.60	4.7μF	±10%	16	0.95
CL31A475KOHNNN □	X5R(EIA)	±15%(-55~+85℃)	3.20 × 1.60	4.7μF	±10%	16	1.80
CL21A106KOCLRN □	X5R(EIA)	±15%(-55~+85℃)	2.00 × 1.25	10μF	±10%	16	0.95
CL21A106KOQNNN □	X5R(EIA)	±15%(-55~+85℃)	2.00 × 1.25	10μF	±10%	16	1.40
CL31A106KOCLNN □	X5R(EIA)	±15%(-55~+85℃)	3.20 × 1.60	10μF	±10%	16	0.95
CL31A106KOHNNN □	X5R(EIA)	±15%(-55~+85℃)	3.20 × 1.60	10μF	±10%	16	1.80
CL31A226KOCLNN □	X5R(EIA)	±15%(-55~+85℃)	3.20 × 1.60	22μF	±10%	16	0.95
CL32A226KOJNNN □	X5R(EIA)	±15%(-55~+85℃)	3.20 × 2.50	22μF	±10%	16	2.70
CL05A224KP5NNN □	X5R(EIA)	±15%(-55~+85℃)	1.00 × 0.50	0.22μF	±10%	10	0.55
CL05A474KP5NNN □	X5R(EIA)	±15%(-55~+85℃)	1.00 × 0.50	0.47μF	±10%	10	0.55
CL10A684KP8NNN □	X5R(EIA)	±15%(-55~+85℃)	1.60 × 0.80	0.68μF	±10%	10	0.90
CL05A105KP5NNN □	X5R(EIA)	±15%(-55~+85℃)	1.00 × 0.50	1.0μF	±10%	10	0.55
CL21A105KPFNNN □	X5R(EIA)	±15%(-55~+85℃)	2.00 × 1.25	1.0μF	±10%	10	1.35
CL05A225KP5NSN □	X5R(EIA)	±15%(-55~+85℃)	1.00 × 0.50	2.2μF	±10%	10	0.55
CL10A225KP8NNN □	X5R(EIA)	±15%(-55~+85℃)	1.60 × 0.80	2.2μF	±10%	10	0.90
CL21A225KPFNNN □	X5R(EIA)	±15%(-55~+85℃)	2.00 × 1.25	2.2μF	±10%	10	1.20
CL21A225KPFNNN □	X5R(EIA)	±15%(-55~+85℃)	2.00 × 1.25	2.2μF	±10%	10	1.35
CL10A475KPLNN □	X5R(EIA)	±15%(-55~+85℃)	1.60 × 0.80	4.7μF	±10%	10	0.55
CL10A475KP8NNN □	X5R(EIA)	±15%(-55~+85℃)	1.60 × 0.80	4.7μF	±10%	10	0.90

※ □ mark means packaging code. If you want to learn the code or quantity in detail, please see p 59.

Product Line UP (Ultra High Capacitors)

Part Number	TC Code	Temperature Characteristics	Size L × W (mm)	Capacitance	Capacitance Tolerance	Rated Voltage (Vdc)	Thickness Max. (mm)
CL21A475KPCLLN □	X5R(EIA)	±15%(-55~+85℃)	2.00 × 1.25	4.7μF	±10%	10	0.95
CL21A475KPFNNN □	X5R(EIA)	±15%(-55~+85℃)	2.00 × 1.25	4.7μF	±10%	10	1.35
CL31A475KP6LNN □	X5R(EIA)	±15%(-55~+85℃)	3.20 × 1.60	4.7μF	±10%	10	0.70
CL10A106KP8NNN □	X5R(EIA)	±15%(-55~+85℃)	1.60 × 0.80	10μF	±10%	10	0.90
CL21A106KPCLLN □	X5R(EIA)	±15%(-55~+85℃)	2.00 × 1.25	10μF	±10%	10	0.95
CL21A106KPFNNN □	X5R(EIA)	±15%(-55~+85℃)	2.00 × 1.25	10μF	±10%	10	1.35
CL31A106KPLNN □	X5R(EIA)	±15%(-55~+85℃)	3.20 × 1.60	10μF	±10%	10	1.25
CL31A106KPHNNN □	X5R(EIA)	±15%(-55~+85℃)	3.20 × 1.60	10μF	±10%	10	1.80
CL21A226MPCLRN □	X5R(EIA)	±15%(-55~+85℃)	2.00 × 1.25	22μF	±10%	10	0.95
CL31A106KPCLLN □	X5R(EIA)	±15%(-55~+85℃)	3.20 × 1.60	22μF	±10%	10	0.95
CL31A226KPHNNN □	X5R(EIA)	±15%(-55~+85℃)	3.20 × 1.60	22μF	±10%	10	1.80
CL32A226KPIJNNN □	X5R(EIA)	±15%(-55~+85℃)	.20 × 2.50	22μF	±10%	10	2.70
CL05A224KQ5NNN □	X5R(EIA)	±15%(-55~+85℃)	1.00 × 0.50	0.22μF	±10%	6.3	0.55
CL05A334KQ5NNN □	X5R(EIA)	±15%(-55~+85℃)	1.00 × 0.50	0.33μF	±10%	6.3	0.55
CL05A474KQ5NNN □	X5R(EIA)	±15%(-55~+85℃)	1.00 × 0.50	0.47μF	±10%	6.3	0.55
CL05A105KQ5NNN □	X5R(EIA)	±15%(-55~+85℃)	1.00 × 0.50	1.0μF	±10%	6.3	0.55
CL05A225KQ5NSN □	X5R(EIA)	±15%(-55~+85℃)	1.00 × 0.50	2.2μF	±10%	6.3	0.57
CL10A225KQ5LNN □	X5R(EIA)	±15%(-55~+85℃)	1.60 × 0.80	2.2μF	±10%	6.3	0.55
CL10A225KQ8NNN □	X5R(EIA)	±15%(-55~+85℃)	1.60 × 0.80	2.2μF	±10%	6.3	0.90
CL10A335KQ8NNN □	X5R(EIA)	±15%(-55~+85℃)	1.60 × 0.80	3.3μF	±10%	6.3	0.90
CL05A475KQ5NRN □	X5R(EIA)	±15%(-55~+85℃)	1.00 × 0.50	4.7μF	±10%	6.3	0.65
CL10A475KQ5NNN □	X5R(EIA)	±15%(-55~+85℃)	1.60 × 0.80	4.7μF	±10%	6.3	0.55
CL10A475KQ8NNN □	X5R(EIA)	±15%(-55~+85℃)	1.60 × 0.80	4.7μF	±10%	6.3	0.90
CL21A475KQCLNN □	X5R(EIA)	±15%(-55~+85℃)	2.00 × 1.25	4.7μF	±10%	6.3	0.95
CL21A475KQFNNN □	X5R(EIA)	±15%(-55~+85℃)	2.00 × 1.25	4.7μF	±10%	6.3	1.35
CL10A106KQ8NNN □	X5R(EIA)	±15%(-55~+85℃)	1.60 × 0.80	10μF	±10%	6.3	0.90
CL21A106KQCLNN □	X5R(EIA)	±15%(-55~+85℃)	2.00 × 1.25	10μF	±10%	6.3	0.95
CL21A106KQFNNN □	X5R(EIA)	±15%(-55~+85℃)	2.00 × 1.25	10μF	±10%	6.3	1.35
CL31A106KQHNNN □	X5R(EIA)	±15%(-55~+85℃)	3.20 × 1.60	10μF	±10%	6.3	1.80
CL31A156KQHNNN □	X5R(EIA)	±15%(-55~+85℃)	3.20 × 1.60	15μF	±10%	6.3	1.80
CL10A226MQ8NRN □	X5R(EIA)	±15%(-55~+85℃)	1.60 × 0.80	22μF	±20%	6.3	1.00
CL21A226MQCLRN □	X5R(EIA)	±15%(-55~+85℃)	2.00 × 1.25	22μF	±20%	6.3	0.95
CL21A226MQQNNN □	X5R(EIA)	±15%(-55~+85℃)	2.00 × 1.25	22μF	±20%	6.3	1.40
CL31A226KQHNNN □	X5R(EIA)	±15%(-55~+85℃)	3.20 × 1.60	22μF	±10%	6.3	1.80
CL32A226MQCLNN □	X5R(EIA)	±15%(-55~+85℃)	3.20 × 2.50	22μF	±20%	6.3	0.95
CL32A226KQJNNN □	X5R(EIA)	±15%(-55~+85℃)	3.20 × 2.50	22μF	±10%	6.3	2.70
CL21A476MQYNNN □	X5R(EIA)	±15%(-55~+85℃)	2.00 × 1.25	47μF	±20%	6.3	1.45
CL31A476MQHNNN □	X5R(EIA)	±15%(-55~+85℃)	3.20 × 1.60	47μF	±20%	6.3	1.80
CL32A476MQJNNN □	X5R(EIA)	±15%(-55~+85℃)	3.20 × 2.50	47μF	±20%	6.3	2.70
CL43A476MQJNNN □	X5R(EIA)	±15%(-55~+85℃)	4.50 × 3.20	47μF	±20%	6.3	2.70
CL32A107MQVNNN □	X5R(EIA)	±15%(-55~+85℃)	3.20 × 2.50	100μF	±20%	6.3	2.80
CL43A107KQLNNN □	X5R(EIA)	±15%(-55~+85℃)	4.50 × 3.20	100μF	±20%	6.3	3.50
CL05A225KR5NNN □	X5R(EIA)	±15%(-55~+85℃)	1.00 × 0.50	2.2μF	±10%	4	0.55
CL10A106KR8NNN □	X5R(EIA)	±15%(-55~+85℃)	1.60 × 0.80	10μF	±10%	4	0.90
CL10A226MR8NQ □	X5R(EIA)	±15%(-55~+85℃)	1.60 × 0.80	22μF	±20%	4	0.95
CL21A476MR5YNNN □	X5R(EIA)	±15%(-55~+85℃)	2.00 × 1.25	47μF	±20%	4	1.45

※ □ mark means packaging code. If you want to learn the code or quantity in detail, please see p 59.

Product Line UP (Ultra High Capacitors)

Part Number	TC Code	Temperature Characteristics	Size L × W (mm)	Capacitance	Capacitance Tolerance	Rated Voltage (Vdc)	Thickness Max. (mm)
CL21X106KAYNNN □	X6S(EIA)	±22%(-55~+105℃)	2.00 × 1.25	10 μ F	±10%	25	1.45
CL31X106KAHNNN □	X6S(EIA)	±22%(-55~+105℃)	3.20 × 1.60	10 μ F	±10%	25	1.80
CL21X106KOYNNN □	X6S(EIA)	±22%(-55~+105℃)	2.00 × 1.25	10 μ F	±10%	16	1.45
CL21X106KPCLNN □	X6S(EIA)	±22%(-55~+105℃)	2.00 × 1.25	10 μ F	±10%	10	0.95
CL05X105KQ5NNN □	X6S(EIA)	±22%(-55~+105℃)	1.00 × 0.50	1.0 μ F	±10%	6.3	0.55
CL10X105KQ8NNN □	X6S(EIA)	±22%(-55~+105℃)	1.60 × 0.80	1.0 μ F	±10%	6.3	0.90
CL21X225KQFNNN □	X6S(EIA)	±22%(-55~+105℃)	2.00 × 1.25	2.2 μ F	±10%	6.3	1.35
CL21X475KQFNNN □	X6S(EIA)	±22%(-55~+105℃)	2.00 × 1.25	4.7 μ F	±10%	6.3	1.35
CL10X106KQ8NNN □	X5R(EIA)	±15%(-55~+85℃)	1.60 × 0.80	10 μ F	±10%	6.3	0.90
CL21X106KQNNN □	X6S(EIA)	±22%(-55~+105℃)	2.00 × 1.25	10 μ F	±10%	6.3	1.40
CL31X106KQHNNN □	X6S(EIA)	±22%(-55~+105℃)	3.20 × 1.60	10 μ F	±10%	6.3	1.80
CL21X226KQNNN □	X6S(EIA)	±22%(-55~+105℃)	2.00 × 1.25	22 μ F	±10%	6.3	1.40
CL21X106KRCLNN □	X6S(EIA)	±22%(-55~+105℃)	2.00 × 1.25	10 μ F	±10%	4	0.95
CL31B475KAHNNN □	X7R(EIA)	±15%(-55~+125℃)	3.20 × 1.60	4.7 μ F	±10%	25	1.80
CL31B106KAHNNN □	X7R(EIA)	±15%(-55~+125℃)	3.20 × 1.60	10 μ F	±10%	25	1.80
CL31B475KOHNNN □	X7R(EIA)	±15%(-55~+125℃)	3.20 × 1.60	4.7 μ F	±10%	16	1.80
CL31B106KOHNNN □	X7R(EIA)	±15%(-55~+125℃)	3.20 × 1.60	10 μ F	±10%	16	1.80
CL21B225KQFNNN □	X7R(EIA)	±15%(-55~+125℃)	2.00 × 1.25	2.2 μ F	±10%	10	1.35
CL21B225KPFNNN □	X7R(EIA)	±15%(-55~+125℃)	2.00 × 1.25	2.2 μ F	±10%	6.3	1.35
CL31B106KQHNNN □	X7R(EIA)	±15%(-55~+125℃)	3.20 × 1.60	10 μ F	±10%	6.3	1.80
CL32B226KQJNNN □	X7R(EIA)	±15%(-55~+125℃)	3.20 × 2.50	22 μ F	±10%	6.3	2.80

Part Number	TC Code	Temperature Characteristics	Size L × W (mm)	Capacitance	Capacitance Tolerance	Rated Voltage (Vdc)	Thickness Max. (mm)
CL10F225ZP8NNN □	Y5V(EIA)	-82~+22%(-30~+85℃)	1.60 × 0.80	2.2 μ F	80% / -20%	10	0.90
CL21F106ZPFNNN □	Y5V(EIA)	-82~+22%(-30~+85℃)	2.00 × 1.25	10 μ F	80% / -20%	10	1.35
CL31F226ZPHNNN □	Y5V(EIA)	-82~+22%(-30~+85℃)	3.20 × 1.60	22 μ F	80% / -20%	10	1.80
CL32F226ZPJNNN □	Y5V(EIA)	-82~+22%(-30~+85℃)	3.20 × 2.50	22 μ F	80% / -20%	10	2.80
CL05F105ZQ5NNN □	Y5V(EIA)	-82~+22%(-30~+85℃)	1.00 × 0.50	1.0 μ F	80% / -20%	6.3	0.55
CL10F475ZQ8NNN □	Y5V(EIA)	-82~+22%(-30~+85℃)	1.60 × 0.80	4.7 μ F	80% / -20%	6.3	0.90
CL32F107ZQJNNN □	Y5V(EIA)	-82~+22%(-30~+85℃)	3.20 × 2.50	100 μ F	80% / -20%	6.3	2.80

※ □ mark means packaging code. If you want to learn the code or quantity in detail, please see p 59.

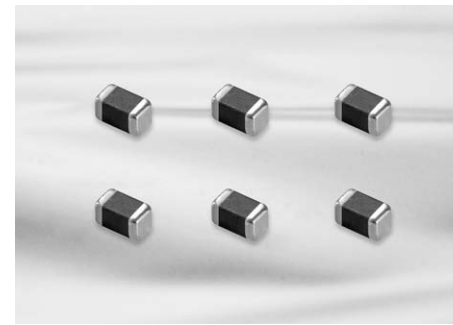

Feature

- Small chip size(0.6×0.3×0.3 mm)
- 03 Series(COG) MLCC shows very low ESR value.
- 03 Series are suited to only reflow soldering
- 03 Series are suited to miniature RF module, portable equipment and high frequency circuit

Application

- VCO, Tuner, RF Module
- MCM Module
- Mobile phone, Wireless LAN, Note PC

Structure and Dimensions

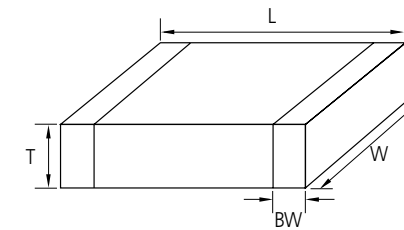

Code	EIA Code	Dimension(mm)			
		L	W	T	BW
03	0201				

Capacitance Table (Super Small Size Capacitors)

Size	0201(03)					
	COG(C)		X7R(B) / X5R(A)			Y5V(F)
	25(A)	50(B)	6.3(Q)	10(P)	16(O)	6.3(Q)
Capacitance -pF- (part numbering code) and thickness -mm- (part numbering code)						
0.5(0R5)						
0.75(R75)						
1.0(010)						
2.0(020)						
3.0(030)						
4.0(040)						
5.0(050)						
6.0(060)						
7.0(070)		0.3 (3)				
8.0(080)						
9.0(090)						
10(100)						
12(120)						
15(150)						
18(180)						
20(200)						
22(220)						
27(270)						
33(330)						
39(390)						
47(470)	0.3 (3)					
56(560)						
68(680)						
82(820)						
100(101)						
150(151)						
220(221)						
330(331)						
470(471)						
680(681)						
1000(102)						
1500(152)						
2200(222)						
3300(332)						
4700(472)						
6800(682)						
10000(103)						
15000(153)						
22000(223)						
33000(333)						
47000(473)						
68000(683)						
100000(104)						

■:X7R(B) ■:X5R(A) ■:Y5V(F) ▨:COG(C) ▩:X6S(X)

Product Line UP (Super Small Size Capacitors)

Part Number	TC Code	Temperature Characteristics	Size L × W (mm)	Capacitance	Capacitance Tolerance	Rated Voltage (Vdc)	Thickness Max. (mm)	Remark
CL03C0R5CA3GNN □	COG(EIA)	±30ppm/°C (-55~+125°C)	0.60 × 0.30	0.5pF	±0.25pF	25	0.33	High-Q
CL03C010CA3GNN □	COG(EIA)	±30ppm/°C (-55~+125°C)	0.60 × 0.30	1.0pF	±0.25pF	25	0.33	High-Q
CL03C1R2CA3GNN □	COG(EIA)	±30ppm/°C (-55~+125°C)	0.60 × 0.30	1.2pF	±0.25pF	25	0.33	High-Q
CL03C1R5CA3GNN □	COG(EIA)	±30ppm/°C (-55~+125°C)	0.60 × 0.30	1.5pF	±0.25pF	25	0.33	High-Q
CL03C1R8CA3GNN □	COG(EIA)	±30ppm/°C (-55~+125°C)	0.60 × 0.30	1.8pF	±0.25pF	25	0.33	High-Q
CL03C020CA3GNN □	COG(EIA)	±30ppm/°C (-55~+125°C)	0.60 × 0.30	2.0pF	±0.25pF	25	0.33	High-Q
CL03C2R2CA3GNN □	COG(EIA)	±30ppm/°C (-55~+125°C)	0.60 × 0.30	2.2pF	±0.25pF	25	0.33	High-Q
CL03C2R7CA3GNN □	COG(EIA)	±30ppm/°C (-55~+125°C)	0.60 × 0.30	2.7pF	±0.25pF	25	0.33	High-Q
CL03C030CA3GNN □	COG(EIA)	±30ppm/°C (-55~+125°C)	0.60 × 0.30	3.0pF	±0.25pF	25	0.33	High-Q
CL03C3R3CA3GNN □	COG(EIA)	±30ppm/°C (-55~+125°C)	0.60 × 0.30	3.3pF	±0.25pF	25	0.33	High-Q
CL03C3R9CA3GNN □	COG(EIA)	±30ppm/°C (-55~+125°C)	0.60 × 0.30	3.9pF	±0.25pF	25	0.33	High-Q
CL03C4R7CA3GNN □	COG(EIA)	±30ppm/°C (-55~+125°C)	0.60 × 0.30	4.7pF	±0.25pF	25	0.33	High-Q
CL03C5R6DA3GNN □	COG(EIA)	±30ppm/°C (-55~+125°C)	0.60 × 0.30	5.6pF	±0.5pF	25	0.33	High-Q
CL03C6R8DA3GNN □	COG(EIA)	±30ppm/°C (-55~+125°C)	0.60 × 0.30	6.8pF	±0.5pF	25	0.33	High-Q
CL03C8R2DA3GNN □	COG(EIA)	±30ppm/°C (-55~+125°C)	0.60 × 0.30	8.2pF	±0.5pF	25	0.33	High-Q
CL03C090DA3GNN □	COG(EIA)	±30ppm/°C (-55~+125°C)	0.60 × 0.30	9.0pF	±0.5pF	25	0.33	High-Q
CL03C100JA3GNN □	COG(EIA)	±30ppm/°C (-55~+125°C)	0.60 × 0.30	10pF	±5%	25	0.33	High-Q
CL03C150JA3GNN □	COG(EIA)	±30ppm/°C (-55~+125°C)	0.60 × 0.30	15pF	±5%	25	0.33	High-Q
CL03C180JA3GNN □	COG(EIA)	±30ppm/°C (-55~+125°C)	0.60 × 0.30	18pF	±5%	25	0.33	High-Q
CL03C220JA3GNN □	COG(EIA)	±30ppm/°C (-55~+125°C)	0.60 × 0.30	22pF	±5%	25	0.33	High-Q
CL03C270JA3GNN □	COG(EIA)	±30ppm/°C (-55~+125°C)	0.60 × 0.30	27pF	±5%	25	0.33	High-Q
CL03C330JA3GNN □	COG(EIA)	±30ppm/°C (-55~+125°C)	0.60 × 0.30	33pF	±5%	25	0.33	High-Q
CL03C390JA3ANN □	COG(EIA)	±30ppm/°C (-55~+125°C)	0.60 × 0.30	39pF	±5%	25	0.33	
CL03C470JA3ANN □	COG(EIA)	±30ppm/°C (-55~+125°C)	0.60 × 0.30	47pF	±5%	25	0.33	
CL03C101JA3ANN □	COG(EIA)	±30ppm/°C (-55~+125°C)	0.60 × 0.30	100pF	±5%	25	0.33	

※ □ mark means packaging code. If you want to learn the code or quantity in detail, please see p 59.

Super Small Size Capacitors

Product Line UP (Super Small Size Capacitors)

Part Number	TC Code	Temperature Characteristics	Size L × W (mm)	Capacitance	Capacitance Tolerance	Rated Voltage (Vdc)	Thickness Max. (mm)
CL03B331K03NNN □	X7R(EIA)	±15%(-55~+125℃)	0.60 × 0.30	0.33nF	±10%	16	0.33
CL03B102K03NNN □	X7R(EIA)	±15%(-55~+125℃)	0.60 × 0.30	1.0nF	±10%	16	0.33
CL03B472K03NNN □	X7R(EIA)	±15%(-55~+125℃)	0.60 × 0.30	4.7nF	±10%	10	0.33
CL03A103K03NNN □	X5R(EIA)	±15%(-55~+85℃)	0.60 × 0.30	10nF	±10%	10	0.33
CL03B103K03NNN □	X7R(EIA)	±15%(-55~+125℃)	0.60 × 0.30	10nF	±10%	10	0.33
CL03A104K03NNN □	X5R(EIA)	±15%(-55~+85℃)	0.60 × 0.30	100nF	±10%	10	0.33
CL03B472K03NNN □	X7R(EIA)	±15%(-55~+125℃)	0.60 × 0.30	4.7nF	±10%	6.3	0.33
CL03A223K03NNN □	X5R(EIA)	±15%(-55~+85℃)	0.60 × 0.30	22nF	±10%	6.3	0.33
CL03A473K03NNN □	X5R(EIA)	±15%(-55~+85℃)	0.60 × 0.30	47nF	±10%	6.3	0.33
CL03A104K03NNN □	X5R(EIA)	±15%(-55~+85℃)	0.60 × 0.30	100nF	±10%	6.3	0.33

※ □mark means packaging code. If you want to learn the code or quantity in detail, please see p 59.

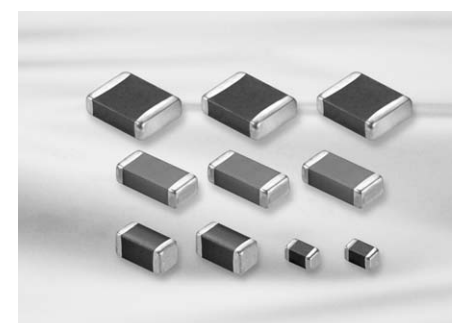

Feature

- Highly reliable performance
- Operating at high voltage level
- Wide voltage level: from 100V to 3000V
- High withstanding voltage
- Tape & reel surface mount assembly

Application

- Switching Power Circuit(SMPS)
- Lighting Ballast, LCD back lighting inverter
- DC-DC converter input filter, snubber circuit
- Tip & Ring(Phone, Fax, Modem)
- Network(IEEE802.3)

Structure and Dimensions

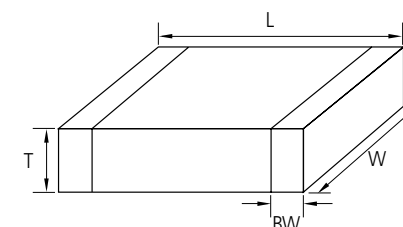

Code	EIA Code	Dimension(mm)			
		L	W	T	BW
10	0603	1.6±0.1	0.8±0.1	0.8±0.1	0.3±0.2
21	0805	2.0±0.1	1.25±0.1	1.25±0.1	0.5+0.2/-0.3
31	1206	3.2±0.2	1.6±0.2	1.6±0.2	0.5±0.3
		3.2±0.15	1.6±0.15	0.85±0.15	
32	1210	3.2±0.3	2.5±0.2	2.5±0.2	0.6±0.3
42	1808	4.5±0.4	2.0±0.2	2.0±0.2	0.8±0.3
43	1812	4.5±0.4	3.2±0.3	2.5±0.2	0.8±0.3
55	2220	5.7±0.4	5.0±0.4	2.5±0.2	1.0±0.3

Capacitance Table (High Voltage Capacitors)

Size	0603(10)		0805(21)			1206(31)						
	TC										COG(C)	
Rated V	100(C)	250(E)	100(C)	200(D)	250(E)	100(C)	200(D)	250(E)	500(G)	630(H)	1000(I)	2000(J)
Capacitance -pF- (part numbering code) and thickness -mm-												
0.5(0R5) ~9.1(9R1)												
10(100) ~27(270)												
33(330)												1.6 (H)
39(390)												
47(470)			0.65 (A)									
56(560)		0.80 (8)										
68(680)		0.80 (8)		0.85 (C)	0.85 (C)				1.25 (F)	1.25 (F)		
82(820) ~180(181)	0.80 (8)											
220(221) ~390(391)						0.85 (C)					1.6 (H)	150 270
470(471)							0.85 (C)	0.85 (C)				
560(561)												
680(681)			0.85 (C)									
820(821)				1.25 (F)								
1000(102)							1.25 (F)	1.25 (F)				
1200(122)					1.25 (F)							
1500(152)									1.6 (H)	1.6 (H)		
1800(182)												
2200(222)			1.25 (F)				1.6 (H)					
2700(272)												
3300(332)												
3900(392)								1.6 (H)				
4700(472)												
5600(562)												
6800(682)												
8200(822)						1.6 (H)						
10000(103)												
15000(153)												
18000(183)												

:X7R(B) :X5R(A) :Y5V(F) :COG(C) :X6S(X)

Capacitance Table (High Voltage Capacitors)

Size	1210(32)							1808(42)		
	TC									COG(C)
Rated V	100(C)	200(D)	250(E)	500(G)	630(H)	1000(I)	2000(J)	2000(J)	3000(K)	
Capacitance -pF- (part numbering code) and thickness -mm-										
10(100)										
12(120)										
15(150)										
18(180)										
22(220)										
27(270)										
33(330)										
39(390)										
47(470)										
56(560)										
68(680)										
82(820)								1.25 (F)		
100(101)										
120(121)										
150(151)										
180(181)										
220(221)								1.6 (H)		
270(271)								2.0 (I)		
330(331)										
390(391)								2.5 (U)		
470(471)										
560(561)										
680(681)					1.25 (F)		1.25 (F)			
820(821)										
1000(102)										
1200(122)										
1500(152)										
1800(182)										
2200(222)										
2700(272)										
3300(332)										
3900(392)										
4700(472)										
5600(562)	1.25 (F)									
6800(682)										
8200(822)										
10000(103)	1.6 (H)									
12000(123)	2.0 (I)									
15000(153)										
18000(183)										
27000(273)										
39000(393)										
47000(473)										
56000(563)										

:X7R(B) :X5R(A) :Y5V(F) :COG(C) :X6S(X)

Capacitance Table (High Voltage Capacitors)

Size	1812(43)						2220(55)						
TC	COG(C)												
Rated V	100(C)	200(D)	250(E)	500(G)	630(H)	1000(I)	2000(J)	3000(K)	250(E)	500(G)	630(H)	1000(I)	3000(K)
Capacitance -pF- (part numbering code) and thickness -mm-													
47(470)							1.25 (F)						
82(820)													
100(101)													
120(121)													
150(151)													
180(181)													
220(221)													
270(271)													
390(391)													
470(471)													
680(681)													
820(821)													
1000(102)													
1200(122)													
1500(152)													
1800(182)													
2200(222)													
2700(272)													
3300(332)													
3600(362)													
4700(472)													
5600(562)													
6800(682)													
8200(822)													
10000(103)													
12000(123)													
15000(153)													
18000(183)													
22000(223)													
27000(273)													
33000(333)													
39000(393)													
47000(473)													
68000(683)													

Legend: :X7R(B) :X5R(A) :Y5V(F) :COG(C) :X6S(X)

Capacitance Table (High Voltage Capacitors)

Size	0603(10)	0805(21)			1206(31)						
TC	X7R(B)										
Rated V	100(C)	100(C)	200(D)	250(E)	100(C)	200(D)	250(E)	500(G)	630(H)	1000(I)	2000(J)
Capacitance -pF- (part numbering code) and thickness -mm-											
220(221)											
330(331)											
470(471)											
680(681)											
1000(102)											
1500(152)											
2200(222)											
3300(332)											
4700(472)											
6800(682)											
10000(103)											
15000(153)											
22000(223)											
33000(333)											
47000(473)											
68000(683)											
100000(104)											
150000(154)											
1000000(105)											

Size	1210(32)						1808(42)
TC	X7R(B)						
Rated V	100(C)	250(E)	500(G)	630(H)	1000(I)	2000(J)	2000(J)

Capacitance -pF- (part numbering code) and thickness -mm-							
470(471)							
1000(102)							
2200(222)							
3300(332)							
4700(472)							
6800(682)							
10000(103)							
15000(153)							
22000(223)							
33000(333)							
47000(473)							
68000(683)							
100000(104)							
150000(154)							
220000(224)							
330000(334)							
470000(474)							
680000(684)							
1000000(105)							

Legend: :X7R(B) :X5R(A) :Y5V(F) :COG(C) :X6S(X)

Capacitance Table (High Voltage Capacitors)

Size TC Rated V	1812(43)						2220(55)					
	X7R(B)											
	100(C)	200(D)	250(E)	500(G)	1000(I)	2000(J)	100(C)	200(D)	250(E)	500(G)	1000(I)	2000(J)
Capacitance -pF- (part numbering code) and thickness -mm-												
1000(102)												
1500(152)												
1800(182)						1.25 (F)						
2700(272)												
3300(332)												
3900(392)						1.25 (F)						
4700(472)												
5600(562)												1.6 (H)
6800(682)												
8200(822)												
10000(103)												
12000(123)						1.6 (H)						
15000(153)												
18000(183)												
22000(223)					1.25 (F)							
27000(273)						2.5 (J)						
33000(333)												
39000(393)												
47000(473)											2.0 (I)	
56000(563)												
68000(683)		1.25 (F)			1.6 (H)							
82000(823)					2.0 (I)							
100000(104)												
120000(124)												
150000(154)									1.6 (H)			
180000(184)	1.25 (F)								2.0 (I)		2.5 (J)	
220000(224)												
270000(274)			2.5 (J)						2.5 (J)			
330000(334)												
470000(474)	1.6 (H)									2.5 (J)		
560000(564)	2.0 (I)											
680000(684)												
820000(824)	2.5 (J)						1.6 (H)					
1000000(105)												
1500000(155)							2.0 (I)					
2200000(225)												
3300000(335)												
4700000(475)							2.5 (J)					

■:X7R(B) ■:X5R(A) ■:Y5V(F) ■:COG(C) ■:X6S(X)

Product Line UP (High Voltage Capacitors)

Part Number	TC Code	Temperature Characteristics	Rated Voltage (Vdc)	Size L×W (mm)	Capacitance	Capacitance Tolerance	Thickness Max. (mm)
CL42C100JKFNNN □	COG(EIA)	±30ppm/°C(-55~+125°C)	3000	4.50X2.00	10pF	±5%	1.35
CL31C220JJHNNN □	COG(EIA)	±30ppm/°C(-55~+125°C)	2000	3.20X1.60	22pF	±5%	1.80
CL31C470JJHNNN □	COG(EIA)	±30ppm/°C(-55~+125°C)	2000	3.20X1.60	47pF	±5%	1.80
CL32C101JJFNNN □	COG(EIA)	±30ppm/°C(-55~+125°C)	2000	3.20X2.50	100pF	±5%	1.35
CL31C680JIFNNN □	COG(EIA)	±30ppm/°C(-55~+125°C)	1000	3.20X1.60	68pF	±5%	1.35
CL31C101JIFNNN □	COG(EIA)	±30ppm/°C(-55~+125°C)	1000	3.20X1.60	100pF	±5%	1.35
CL43C102JIHNNN □	COG(EIA)	±30ppm/°C(-55~+125°C)	1000	4.50X3.20	1.0nF	±5%	1.80
CL43C122JIHNNN □	COG(EIA)	±30ppm/°C(-55~+125°C)	1000	4.50X3.20	1.2nF	±5%	2.20
CL43C182JIHNNN □	COG(EIA)	±30ppm/°C(-55~+125°C)	1000	4.50X3.20	1.8nF	±5%	2.80
CL31C470JHFNNN □	COG(EIA)	±30ppm/°C(-55~+125°C)	630	3.20X1.60	47pF	±5%	1.35
CL31C680JHFNNN □	COG(EIA)	±30ppm/°C(-55~+125°C)	630	3.20X1.60	68pF	±5%	1.35
CL31C101JHFNNN □	COG(EIA)	±30ppm/°C(-55~+125°C)	630	3.20X1.60	100pF	±5%	1.35
CL31C150JGFNNN □	COG(EIA)	±30ppm/°C(-55~+125°C)	500	3.20X1.60	15pF	±5%	1.35
CL31C180JGFNNN □	COG(EIA)	±30ppm/°C(-55~+125°C)	500	3.20X1.60	18pF	±5%	1.35
CL31C220JGFNNN □	COG(EIA)	±30ppm/°C(-55~+125°C)	500	3.20X1.60	22pF	±5%	1.35
CL31C270JGFNNN □	COG(EIA)	±30ppm/°C(-55~+125°C)	500	3.20X1.60	27pF	±5%	1.35
CL31C330JGFNNN □	COG(EIA)	±30ppm/°C(-55~+125°C)	500	3.20X1.60	33pF	±5%	1.35
CL31C390JGFNNN □	COG(EIA)	±30ppm/°C(-55~+125°C)	500	3.20X1.60	39pF	±5%	1.35
CL31C470JGFNNN □	COG(EIA)	±30ppm/°C(-55~+125°C)	500	3.20X1.60	47pF	±5%	1.35
CL31C560JGFNNN □	COG(EIA)	±30ppm/°C(-55~+125°C)	500	3.20X1.60	56pF	±5%	1.35
CL31C680JGFNNN □	COG(EIA)	±30ppm/°C(-55~+125°C)	500	3.20X1.60	68pF	±5%	1.35
CL31C820JGFNCC □	COG(EIA)	±30ppm/°C(-55~+125°C)	500	3.20X1.60	82pF	±5%	1.35
CL31C101JGFNCC □	COG(EIA)	±30ppm/°C(-55~+125°C)	500	3.20X1.60	100pF	±5%	1.35
CL31C121JGFNCC □	COG(EIA)	±30ppm/°C(-55~+125°C)	500	3.20X1.60	120pF	±5%	1.35
CL31C151JGFNCC □	COG(EIA)	±30ppm/°C(-55~+125°C)	500	3.20X1.60	150pF	±5%	1.35
CL31C181JGFNCC □	COG(EIA)	±30ppm/°C(-55~+125°C)	500	3.20X1.60	180pF	±5%	1.35
CL31C221JGFNCC □	COG(EIA)	±30ppm/°C(-55~+125°C)	500	3.20X1.60	220pF	±5%	1.35
CL31C271JGFNCC □	COG(EIA)	±30ppm/°C(-55~+125°C)	500	3.20X1.60	270pF	±5%	1.35
CL31C331JGFNCC □	COG(EIA)	±30ppm/°C(-55~+125°C)	500	3.20X1.60	330pF	±5%	1.35
CL31C471JGFNCC □	COG(EIA)	±30ppm/°C(-55~+125°C)	500	3.20X1.60	470pF	±5%	1.35
CL31C561JGFNCC □	COG(EIA)	±30ppm/°C(-55~+125°C)	500	3.20X1.60	560pF	±5%	1.35
CL31C681JGFNCC □	COG(EIA)	±30ppm/°C(-55~+125°C)	500	3.20X1.60	680pF	±5%	1.80
CL31C102JGHNNN □	COG(EIA)	±30ppm/°C(-55~+125°C)	500	3.20X1.60	1.0nF	±5%	1.80
CL21C101JECNNN □	COG(EIA)	±30ppm/°C(-55~+125°C)	250	2.00X1.25	100pF	±5%	1.00
CL21C150JDCNNN □	COG(EIA)	±30ppm/°C(-55~+125°C)	200	2.00X1.25	15pF	±5%	1.00

※ □ mark means packaging code. If you want to learn the code or quantity in detail, please see p 59.

High Voltage Capacitors

Product Line UP (High Voltage Capacitors)

Part Number	TC Code	Temperature Characteristics	Rated Voltage (Vdc)	Size L×W (mm)	Capacitance	Capacitance Tolerance	Thickness Max. (mm)
CL21C180JDCNNN □	COG(EIA)	±30ppm/°C(-55~+125°C)	200	2.00X1.25	18pF	±5%	1.00
CL21C330JDCNNN □	COG(EIA)	±30ppm/°C(-55~+125°C)	200	2.00X1.25	33pF	±5%	1.00
CL21C390JDCNNN □	COG(EIA)	±30ppm/°C(-55~+125°C)	200	2.00X1.25	39pF	±5%	1.00
CL21C470JDCNNN □	COG(EIA)	±30ppm/°C(-55~+125°C)	200	2.00X1.25	47pF	±5%	1.00
CL21C560JDCNNN □	COG(EIA)	±30ppm/°C(-55~+125°C)	200	2.00X1.25	56pF	±5%	1.00
CL21C680JDCNNN □	COG(EIA)	±30ppm/°C(-55~+125°C)	200	2.00X1.25	68pF	±5%	1.00
CL21C101JDCNNN □	COG(EIA)	±30ppm/°C(-55~+125°C)	200	2.00X1.25	100pF	±5%	1.00
CL21C121JDCNNN □	COG(EIA)	±30ppm/°C(-55~+125°C)	200	2.00X1.25	120pF	±5%	1.00
CL21C221JDCNNN □	COG(EIA)	±30ppm/°C(-55~+125°C)	200	2.00X1.25	220pF	±5%	1.00
CL21C102JDFNNN □	COG(EIA)	±30ppm/°C(-55~+125°C)	200	2.00X1.25	1.0nF	±5%	1.35
CL10C100JC8NNN □	COG(EIA)	±30ppm/°C(-55~+125°C)	100	1.60X0.80	10pF	±5%	0.90
CL21C100JCANNN □	COG(EIA)	±30ppm/°C(-55~+125°C)	100	2.00X1.25	10pF	±5%	0.75
CL21C120JCANNN □	COG(EIA)	±30ppm/°C(-55~+125°C)	100	2.00X1.25	12pF	±5%	0.75
CL10C150JC8NNN □	COG(EIA)	±30ppm/°C(-55~+125°C)	100	1.60X0.80	15pF	±5%	0.90
CL21C150JCANNN □	COG(EIA)	±30ppm/°C(-55~+125°C)	100	2.00X1.25	15pF	±5%	0.75
CL21C180JCANNN □	COG(EIA)	±30ppm/°C(-55~+125°C)	100	2.00X1.25	18pF	±5%	0.75
CL21C220JCANNN □	COG(EIA)	±30ppm/°C(-55~+125°C)	100	2.00X1.25	22pF	±5%	0.75
CL21C270JCANNN □	COG(EIA)	±30ppm/°C(-55~+125°C)	100	2.00X1.25	27pF	±5%	0.75
CL21C330JCANNN □	COG(EIA)	±30ppm/°C(-55~+125°C)	100	2.00X1.25	33pF	±5%	0.75
CL10C330JC8NNN □	COG(EIA)	±30ppm/°C(-55~+125°C)	100	1.60X0.80	33pF	±5%	0.90
CL10C390JC8NNN □	COG(EIA)	±30ppm/°C(-55~+125°C)	100	1.60X0.80	39pF	±5%	0.90
CL10C470JC8NNN □	COG(EIA)	±30ppm/°C(-55~+125°C)	100	1.60X0.80	47pF	±5%	0.90
CL21C470JCANNN □	COG(EIA)	±30ppm/°C(-55~+125°C)	100	2.00X1.25	47pF	±5%	0.75
CL21C560JCCNNN □	COG(EIA)	±30ppm/°C(-55~+125°C)	100	2.00X1.25	47pF	±5%	0.75
CL21C680JCANNN □	COG(EIA)	±30ppm/°C(-55~+125°C)	100	2.00X1.25	68pF	±5%	0.75
CL31C680JCCNNN □	COG(EIA)	±30ppm/°C(-55~+125°C)	100	3.20X1.60	68pF	±5%	1.00
CL21C820JCCNNN □	COG(EIA)	±30ppm/°C(-55~+125°C)	100	3.20X1.60	82pF	±5%	1.00
CL10C101JC8NNN □	COG(EIA)	±30ppm/°C(-55~+125°C)	100	1.60X0.80	100pF	±5%	0.90
CL21C101JCANNN □	COG(EIA)	±30ppm/°C(-55~+125°C)	100	2.00X1.25	100pF	±5%	0.75
CL10C121JC8NNN □	COG(EIA)	±30ppm/°C(-55~+125°C)	100	1.60X0.80	120pF	±5%	0.90
CL10C151JC8NNN □	COG(EIA)	±30ppm/°C(-55~+125°C)	100	1.60X0.80	150pF	±5%	0.90
CL21C151JCANNN □	COG(EIA)	±30ppm/°C(-55~+125°C)	100	2.00X1.25	150pF	±5%	0.75
CL21C221JCANNN □	COG(EIA)	±30ppm/°C(-55~+125°C)	100	2.00X1.25	220pF	±5%	0.75
CL31C271JCCNNN □	COG(EIA)	±30ppm/°C(-55~+125°C)	100	3.20X1.60	270pF	±5%	1.00
CL21C331JCANNN □	COG(EIA)	±30ppm/°C(-55~+125°C)	100	2.00X1.25	330pF	±5%	0.75

※ □mark means packaging code. If you want to learn the code or quantity in detail, please see p 59.

Product Line UP (High Voltage Capacitors)

Part Number	TC Code	Temperature Characteristics	Rated Voltage (Vdc)	Size L×W (mm)	Capacitance	Capacitance Tolerance	Thickness Max. (mm)
CL10C331JC8NNN □	COG(EIA)	±30ppm/°C(-55~+125°C)	100	1.60X0.80	330pF	±5%	0.90
CL31C391JCCNNN □	COG(EIA)	±30ppm/°C(-55~+125°C)	100	3.20X1.60	390pF	±5%	1.00
CL10C471JC8NNN □	COG(EIA)	±30ppm/°C(-55~+125°C)	100	1.60X0.80	470pF	±5%	0.90
CL21C471JCCNNN □	COG(EIA)	±30ppm/°C(-55~+125°C)	100	2.00X1.25	470pF	±5%	1.00
CL21C561JCCNNN □	COG(EIA)	±30ppm/°C(-55~+125°C)	100	2.00X1.25	560pF	±5%	1.00
CL31C561JCCNNN □	COG(EIA)	±30ppm/°C(-55~+125°C)	100	3.20X1.60	560pF	±5%	1.00
CL21C681JCCNNN □	COG(EIA)	±30ppm/°C(-55~+125°C)	100	2.00X1.25	680pF	±5%	1.00
CL21C102JCFNNN □	COG(EIA)	±30ppm/°C(-55~+125°C)	100	2.00X1.25	1.0nF	±5%	1.35
CL31C102JCCNNN □	COG(EIA)	±30ppm/°C(-55~+125°C)	100	3.20X1.60	1.0nF	±5%	1.00
CL31C152JCCNNN □	COG(EIA)	±30ppm/°C(-55~+125°C)	100	3.20X1.60	1.5nF	±5%	1.00
CL31C222JCCNNN □	COG(EIA)	±30ppm/°C(-55~+125°C)	100	3.20X1.60	2.2nF	±5%	1.00
CL31C392JCHNNN □	COG(EIA)	±30ppm/°C(-55~+125°C)	100	3.20X1.60	3.9nF	±5%	1.80

Part Number	TC Code	Temperature Characteristics	Rated Voltage (Vdc)	Size L×W (mm)	Capacitance	Capacitance Tolerance	Thickness Max. (mm)
CL31B102KJHNNN □	X7R(EIA)	±15%(-55~+125°C)	2000	3.20×1.60	1.0nF	±10%	1.80
CL32B102KJFNNN □	X7R(EIA)	±15%(-55~+125°C)	2000	3.20×2.50	1.0nF	±10%	1.35
CL43B102KJFNNN □	X7R(EIA)	±15%(-55~+125°C)	2000	4.50×3.20	1.0nF	±10%	1.35
CL43B152KJFNNN □	X7R(EIA)	±15%(-55~+125°C)	2000	4.50×3.20	1.5nF	±10%	1.35
CL31B102KIFNNN □	X7R(EIA)	±15%(-55~+125°C)	1000	3.20×1.60	1.0nF	±10%	1.35
CL31B222KIFNNN □	X7R(EIA)	±15%(-55~+125°C)	1000	3.20×1.60	2.2nF	±10%	1.35
CL43B222KIFNNN □	X7R(EIA)	±15%(-55~+125°C)	1000	4.50×3.20	2.2nF	±10%	1.35
CL43B103KIFNNN □	X7R(EIA)	±15%(-55~+125°C)	1000	4.50×3.20	10nF	±10%	1.35
CL31B102KHFNNN □	X7R(EIA)	±15%(-55~+125°C)	630	3.20×1.60	1.0nF	±10%	1.35
CL32B472KHFNNN □	X7R(EIA)	±15%(-55~+125°C)	630	3.20×2.50	4.7nF	±10%	1.35
CL31B103KHFNNN □	X7R(EIA)	±15%(-55~+125°C)	630	3.20×1.60	10nF	±10%	1.35
CL31B221KGFNNN □	X7R(EIA)	±15%(-55~+125°C)	500	3.20×1.60	0.22nF	±10%	1.35
CL31B471KGFNNN □	X7R(EIA)	±15%(-55~+125°C)	500	3.20×1.60	0.47nF	±10%	1.35
CL31B102KGFNNN □	X7R(EIA)	±15%(-55~+125°C)	500	3.20×1.60	1.0nF	±10%	1.35
CL31B152KGFNNN □	X7R(EIA)	±15%(-55~+125°C)	500	3.20×1.60	1.5nF	±10%	1.35

※ □mark means packaging code. If you want to learn the code or quantity in detail, please see p 59.

High Voltage Capacitors

Product Line UP (High Voltage Capacitors)

Part Number	TC Code	Temperature Characteristics	Rated Voltage (Vdc)	Size L×W (mm)	Capacitance	Capacitance Tolerance	Thickness Max. (mm)
CL31B222KGFNNN □	X7R(EIA)	±15%(-55~+125℃)	500	3.20×1.60	2.2nF	±10%	1.35
CL31B332KGFNNN □	X7R(EIA)	±15%(-55~+125℃)	500	3.20×1.60	3.3nF	±10%	1.35
CL31B472KGFNNN □	X7R(EIA)	±15%(-55~+125℃)	500	3.20×1.60	4.7nF	±10%	1.35
CL31B682KGFNNN □	X7R(EIA)	±15%(-55~+125℃)	500	3.20×1.60	6.8nF	±10%	1.35
CL31B103KGFNNN □	X7R(EIA)	±15%(-55~+125℃)	500	3.20×1.60	10nF	±10%	1.35
CL32B153KGFNNN □	X7R(EIA)	±15%(-55~+125℃)	500	3.20×2.50	15nF	±10%	1.35
CL32B223KGFNNN □	X7R(EIA)	±15%(-55~+125℃)	500	3.20×2.50	22nF	±10%	1.35
CL43B473KGFNNN □	X7R(EIA)	±15%(-55~+125℃)	500	4.50×3.20	47nF	±10%	1.35
CL43B104KGINNN □	X7R(EIA)	±15%(-55~+125℃)	500	4.50×3.20	100nF	±10%	2.20
CL21B153KEFNNN □	X7R(EIA)	±15%(-55~+125℃)	250	2.00×1.25	15nF	±10%	1.35
CL31B473KEHNNN □	X7R(EIA)	±15%(-55~+125℃)	250	3.20×1.60	47nF	±10%	1.80
CL32B104KEJNNN □	X7R(EIA)	±15%(-55~+125℃)	250	3.20×2.50	100nF	±10%	2.80
CL43B474KEJNNN □	X7R(EIA)	±15%(-55~+125℃)	250	4.50×3.20	470nF	±10%	2.80
CL21B221KDCNNN □	X7R(EIA)	±15%(-55~+125℃)	200	2.00×1.25	0.22nF	±10%	1.00
CL21B331KDCNNN □	X7R(EIA)	±15%(-55~+125℃)	200	2.00×1.25	0.33nF	±10%	1.00
CL31B471KDCNNN □	X7R(EIA)	±15%(-55~+125℃)	200	3.20×1.60	0.47nF	±10%	1.00
CL21B102KDCNNN □	X7R(EIA)	±15%(-55~+125℃)	200	2.00×1.25	1.0nF	±10%	1.00
CL21B222KDCNNN □	X7R(EIA)	±15%(-55~+125℃)	200	2.00×1.25	2.2nF	±10%	1.00
CL31B222KDCNNN □	X7R(EIA)	±15%(-55~+125℃)	200	3.20×1.60	2.2nF	±10%	1.00
CL21B472KDCNNN □	X7R(EIA)	±15%(-55~+125℃)	200	2.00×1.25	4.7nF	±10%	1.00
CL31B472KDCNNN □	X7R(EIA)	±15%(-55~+125℃)	200	3.20×1.60	4.7nF	±10%	1.00
CL21B103KDCNNN □	X7R(EIA)	±15%(-55~+125℃)	200	2.00×1.25	10nF	±10%	1.00
CL31B153KDCNNN □	X7R(EIA)	±15%(-55~+125℃)	200	3.20×1.60	15nF	±10%	1.00
CL31B223KDCNNN □	X7R(EIA)	±15%(-55~+125℃)	200	3.20×1.60	22nF	±10%	1.00
CL31B333KDFNNN □	X7R(EIA)	±15%(-55~+125℃)	200	3.20×1.60	33nF	±10%	1.35
CL31B473KDFNNN □	X7R(EIA)	±15%(-55~+125℃)	200	3.20×1.60	47nF	±10%	1.35
CL32B473KDHNNN □	X7R(EIA)	±15%(-55~+125℃)	200	3.20×2.50	47nF	±10%	1.80
CL31B104KDHNNN □	X7R(EIA)	±15%(-55~+125℃)	200	3.20×1.60	100nF	±10%	1.80
CL43B104KDFNNN □	X7R(EIA)	±15%(-55~+125℃)	200	4.50×3.20	100nF	±10%	1.35
CL21B221KCANNN □	X7R(EIA)	±15%(-55~+125℃)	100	2.00×1.25	0.22nF	±10%	0.75
CL21B471KCANNN □	X7R(EIA)	±15%(-55~+125℃)	100	2.00×1.25	0.47nF	±10%	0.75
CL10B102KC8NNN □	X7R(EIA)	±15%(-55~+125℃)	100	1.60×0.80	1.0nF	±10%	0.90
CL21B102KCANNN □	X7R(EIA)	±15%(-55~+125℃)	100	2.00×1.25	1.0nF	±10%	0.75
CL21B222KCANNN □	X7R(EIA)	±15%(-55~+125℃)	100	2.00×1.25	2.2nF	±10%	0.75
CL21B332KCANNN □	X7R(EIA)	±15%(-55~+125℃)	100	2.00×1.25	3.3nF	±10%	0.75

※ □mark means packaging code. If you want to learn the code or quantity in detail, please see p 59.

Product Line UP (High Voltage Capacitors)

Part Number	TC Code	Temperature Characteristics	Rated Voltage (Vdc)	Size L×W (mm)	Capacitance	Capacitance Tolerance	Thickness Max. (mm)
CL10B472KC8NNN □	X7R(EIA)	±15%(-55~+125℃)	100	1.60×0.80	4.7nF	±10%	0.90
CL21B472KCANNN □	X7R(EIA)	±15%(-55~+125℃)	100	2.00×1.25	4.7nF	±10%	0.75
CL21B682KCANNN □	X7R(EIA)	±15%(-55~+125℃)	100	2.00×1.25	6.8nF	±10%	0.75
CL10B103KC8NNN □	X7R(EIA)	±15%(-55~+125℃)	100	1.60×0.80	10nF	±10%	0.90
CL21B103KCANNN □	X7R(EIA)	±15%(-55~+125℃)	100	2.00×1.25	10nF	±10%	0.75
CL32B103KCFNNN □	X7R(EIA)	±15%(-55~+125℃)	100	3.20×2.50	10nF	±10%	1.35
CL21B153KCCNNN □	X7R(EIA)	±15%(-55~+125℃)	100	2.00×1.25	15nF	±10%	1.00
CL31B153KCCNNN □	X7R(EIA)	±15%(-55~+125℃)	100	3.20×1.60	15nF	±10%	1.00
CL21B223KCFNNN □	X7R(EIA)	±15%(-55~+125℃)	100	2.00×1.50	22nF	±10%	1.35
CL31B223KCCNNN □	X7R(EIA)	±15%(-55~+125℃)	100	3.20×1.60	22nF	±10%	1.00
CL31B333KCCNNN □	X7R(EIA)	±15%(-55~+125℃)	100	3.20×1.60	33nF	±10%	1.00
CL21B473KCFNNN □	X7R(EIA)	±15%(-55~+125℃)	100	2.00×1.25	47nF	±10%	1.35
CL31B473KCCNNN □	X7R(EIA)	±15%(-55~+125℃)	100	3.20×1.60	47nF	±10%	1.00
CL31B104KCFNNN □	X7R(EIA)	±15%(-55~+125℃)	100	3.20×1.60	100nF	±10%	1.35
CL31B154KCHNNN □	X7R(EIA)	±15%(-55~+125℃)	100	3.20×1.60	150nF	±10%	1.80
CL32B154KCFNNN □	X7R(EIA)	±15%(-55~+125℃)	100	3.20×2.50	150nF	±10%	1.35
CL32B224KCHNNN □	X7R(EIA)	±15%(-55~+125℃)	100	3.20×2.50	220nF	±10%	1.80
CL43B224KCFNNN □	X7R(EIA)	±15%(-55~+125℃)	100	4.50×3.20	220nF	±10%	1.35
CL32B334KCHNNN □	X7R(EIA)	±15%(-55~+125℃)	100	3.20×2.50	330nF	±10%	1.80
CL43B334KCFNNN □	X7R(EIA)	±15%(-55~+125℃)	100	4.50×3.20	330nF	±10%	1.35
CL32B474KCHNNN □	X7R(EIA)	±15%(-55~+125℃)	100	3.20×2.50	470nF	±10%	2.20
CL43B474KCHNNN □	X7R(EIA)	±15%(-55~+125℃)	100	4.50×3.20	470nF	±10%	1.80
CL31B105KCHNNN □	X7R(EIA)	±15%(-55~+125℃)	100	3.20×1.60	1.0μF	±10%	1.80
CL32B105KCFNNN □	X7R(EIA)	±15%(-55~+125℃)	100	3.20×2.50	1.0μF	±10%	2.80
CL43B105KCFNNN □	X7R(EIA)	±15%(-55~+125℃)	100	4.50×3.20	1.0μF	±10%	2.80
CL55B105KCHNNN □	X7R(EIA)	±15%(-55~+125℃)	100	5.70×5.00	1.0μF	±10%	1.80

※ □mark means packaging code. If you want to learn the code or quantity in detail, please see p 59.

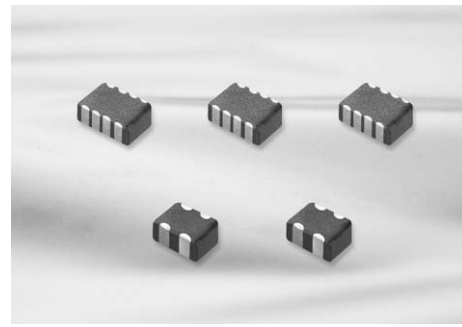

Feature

- Reduction in required space (more than 50%)
- Reduction in cost and time for replacement of PCB
- Reduction in amount of solder joints
- Easier PCB design
- Reduced waste from tape and reel packaging process
- It protect EMI bypassing digital signal line nose

Application

- A bypass for digital and analog signal line noise generated by telecommunication equipment and other common electronic circuits

Structure and Dimensions

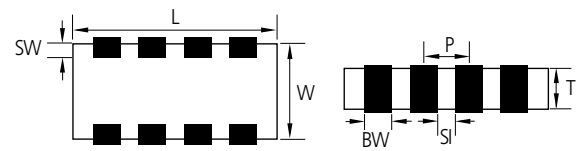

Pd MLCC (12th code in part number of Pd MLCC = A)

- Class I type
Capacitance < 10pF (Class I, 0402, 0603, 0805 case size)
Capacitance > 18pF (Class I, 1206 case size)
- Except the Capacitance range mentioned as above.
All other the Capacitance range is using Ni inner electrode for Class I,
Class II type (12th code in part number of Ni MLCC=N)

Code	EIA Code	Dimension(mm)					
		L	W	T	BW	SW	P
A	0504	1.37±0.15	1.0±0.15	0.60±0.06 0.80±0.08	0.36±0.1	0.2±0.1	0.64±0.1
A	0805	2.0±0.15	1.25±0.15	0.85±0.1	0.5±0.2	0.25±0.15	1.0±0.1
B	0805	2.0±0.15	1.25±0.15	0.85±0.1	0.25±0.1	0.25±0.15	0.5±0.1
B	1206	3.2±0.15	1.6±0.15	0.85±0.15	0.4±0.2	0.3±0.15	0.8±0.2

Structure and Control Code

A: ARRAY(2-element)

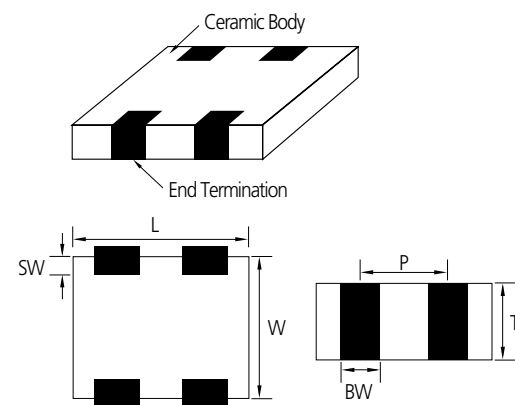

B: ARRAY(4-element)

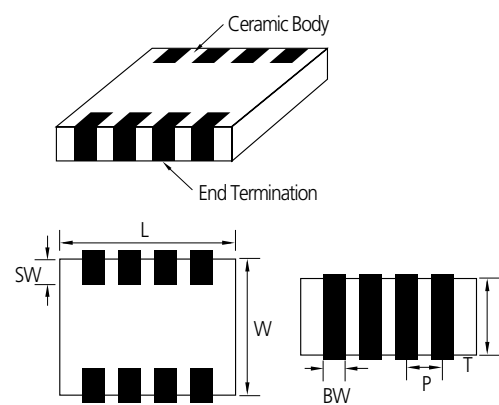

Capacitance Table

Size	0504(14)				0805(21)				1206(31)								
	COG(C)		X7R(B)/X5R(A)		COG(C) X5R		X5R(A)	X7R(B)	COG(C)	X7R(B)	Y5V(F)						
	2 Element		2 Element		2 Element		2	4 Element	4 Element	4 Element							
Rated V	25(A)	50(B)	10(P)	16(O)	25(A)	25(A)	50(B)	25(A)	50(B)	16(O)	16(O)	50(B)	25(A)	50(B)	25(A)	50(B)	
Capacitance -pF- (part numbering code) and T Dimension -mm- (part numbering code)																	
10(100)																	
12(120)																	
15(150)																	
18(180)		0.60(6)					0.85(C)	0.85(C)				0.85(C)					
22(221)																	
27(270)																	
33(330)																	
47(470)																	
56(560)																	
68(680)	0.60(6)																
82(820)																	
100(101)																	
120(121)																	
150(151)							0.85(C)	0.85(C)									
180(181)																	
220(221)																	
270(271)																	
330(331)																	
390(391)																	
470(471)																	
560(561)																	
680(681)																	
820(821)																	
1000(102)																	
1500(152)																	
2200(222)																	
3300(332)																	
4700(472)																	
6800(682)																	
10000(103)																	
1500(153)																	
22000(223)																	
33000(333)																	
47000(473)																	
68000(683)																	
100000(104)																	
150000(154)																	
220000(224)																	
470000(474)																	
680000(684)																	
1000000(105)																	

Legend: :X7R(B) :X5R(A) :COG(C) :Y5V(F)

* Please consult us for special capacitance and high voltage(100V)

Product Line UP (Array Type Capacitors)

Part Number	TC Code	Temperature Characteristics	Element Type	Size L×W (mm)	Capacitance	Capacitance Tolerance	Rated Voltage (Vdc)	Thickness Max. (mm)
CL31C100JBCNBN □	COG(EIA)	±30ppm/°C(-55~+125°C)	4-Array	3.20×1.60	10pF	±5%	50	1.0
CL31C150JBCNBN □	COG(EIA)	±30ppm/°C(-55~+125°C)	4-Array	3.20×1.60	15pF	±5%	50	1.0
CL31C220JBCNBN □	COG(EIA)	±30ppm/°C(-55~+125°C)	4-Array	3.20×1.60	22pF	±5%	50	1.0
CL31C270JBCNBN □	COG(EIA)	±30ppm/°C(-55~+125°C)	4-Array	3.20×1.60	27pF	±10%	50	1.0
CL31C330KBCNBN □	COG(EIA)	±30ppm/°C(-55~+125°C)	4-Array	3.20×1.60	33pF	±10%	50	1.0
CL31C390KBCNBN □	COG(EIA)	±30ppm/°C(-55~+125°C)	4-Array	3.20×1.60	39pF	±10%	50	1.0
CL31C470JBCNBN □	COG(EIA)	±30ppm/°C(-55~+125°C)	4-Array	3.20×1.60	47pF	±5%	50	1.0
CL31C680JBCNBN □	COG(EIA)	±30ppm/°C(-55~+125°C)	4-Array	3.20×1.60	68pF	±5%	50	1.0
CL31C820JBCNBN □	COG(EIA)	±30ppm/°C(-55~+125°C)	4-Array	3.20×1.60	82pF	±5%	50	1.0
CL31C101JBCNBN □	COG(EIA)	±30ppm/°C(-55~+125°C)	4-Array	3.20×1.60	100pF	±5%	50	1.0
CL31C151KBCNBN □	COG(EIA)	±30ppm/°C(-55~+125°C)	4-Array	3.20×1.60	150pF	±10%	50	1.0
CL31C181JBCNBN □	COG(EIA)	±30ppm/°C(-55~+125°C)	4-Array	3.20×1.60	180pF	±5%	50	1.0
CL31C331JBCNBN □	COG(EIA)	±30ppm/°C(-55~+125°C)	4-Array	3.20×1.60	330pF	±5%	50	1.0
CL31C471JBCNBN □	COG(EIA)	±30ppm/°C(-55~+125°C)	4-Array	3.20×1.60	470pF	±5%	50	1.0

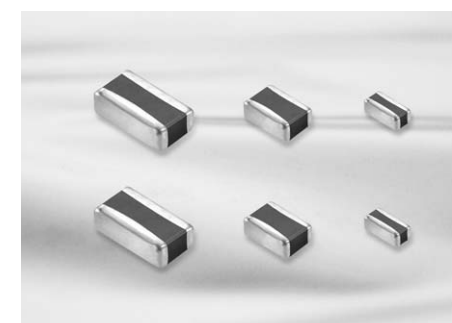

Feature

- Low ESL, good for noise reduction for high frequency
- Highly reliable tolerance and high speed automatic chip placement on PCBs
- Highly reliable performance
- Highly resistant termination metal
- Tape & reel for surface mount assembly

Application

- High Speed Microprocessor
- High Frequency Digital Equipment

Structure and Dimensions

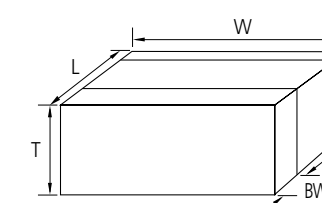

Part Number	TC Code	Temperature Characteristics	Element Type	Size L×W (mm)	Capacitance	Capacitance Tolerance	Rated Voltage (Vdc)	Thickness Max. (mm)
CL21B471KBCNBN □	X7R(EIA)	±15%(-55~+125°C)	4-Array	2.00×1.25	470pF	±5%	50	0.95
CL31B102MBCNBN □	X7R(EIA)	±15%(-55~+125°C)	4-Array	3.20×1.60	1.0nF	±20%	50	1.0
CL31B103MBCNBN □	X7R(EIA)	±15%(-55~+125°C)	4-Array	3.20×1.60	10nF	±20%	50	1.0
CL31B153KBCNBN □	X7R(EIA)	±15%(-55~+125°C)	4-Array	3.20×1.60	15nF	±10%	50	1.0
CL31B473KACNBN □	X7R(EIA)	±15%(-55~+125°C)	4-Array	3.20×1.60	47nF	±10%	25	1.0
CL31F473ZBCNBN □	Y5V(EIA)	-82~+22%(-30~+85°C)	4-Array	3.20×1.60	47nF	80%/±20%	50	1.0
CL31B104KACNBN □	X7R(EIA)	±15%(-55~+125°C)	4-Array	3.20×1.60	100nF	±10%	25	1.0
CL31F104ZACNBN □	Y5V(EIA)	-82~+22%(-30~+85°C)	4-Array	3.20×1.60	100nF	80%/±20%	25	1.0
CL21B104KOCNBN □	X7R(EIA)	±15%(-55~+125°C)	4-Array	2.00×1.25	100nF	±10%	16	0.95
CL31B104KOCNBN □	X7R(EIA)	±15%(-55~+125°C)	4-Array	3.20×1.60	100nF	±10%	16	1.0
CL21B104MPCNBN □	X7R(EIA)	±15%(-55~+125°C)	4-Array	2.00×1.25	100nF	±20%	10	0.95
CL21A105KOCNAN □	X5R(EIA)	±15%(-55~+85°C)	2-Array	2.00×1.25	1.0uF	±10%	16	0.95
CL14A105M08NAN □	X5R(EIA)	±15%(-55~+85°C)	2-Array	1.40×1.00	1.0uF	±20%	16	0.88
CL14A105KP8NAN □	X5R(EIA)	±15%(-55~+85°C)	2-Array	1.40×1.00	1.0uF	±10%	10	0.88
CL21A105MPCNAN □	X5R(EIA)	±15%(-55~+85°C)	2-Array	2.00×1.25	1.0uF	±20%	10	0.95

※ □ mark means packaging code. If you want to learn the code or quantity in detail, please see p 59.

Code	EIA Code	Dimension(mm)			
		L	W	T	BW
01	0306	0.8±0.15	1.6±0.2	0.5+0.05/-0.1	0.15 min.
12	0508	1.25±0.1	2.0±0.1	0.5±0.1 0.85±0.1	0.2 min.
13	0612	1.6±0.2	3.2±0.2	0.85±0.1 1.25±0.15	0.2 min.

Capacitance Table (Low ESL Capacitors)

Size	0204(L5)			0306(01)				0508(12)				0612(13)		
TC	X7S(Y) / X5R(A) / X7R(B)													
Rated V	6.3(Q)	4(R)	6.3(Q)	10(P)	16(O)	25(A)	50(B)	6.3(Q)	10(P)	16(O)	25(A)	50(B)	6.3(Q)	50(B)
Capacitance -uF- (part numbering code)														
0.01(103)							0.5 (5)							
0.015(153)							0.5 (5)							
0.022(223)							0.5 (5)							
0.033(333)							0.5 (5)							
0.047(473)							0.5 (5)							
0.068(683)							0.5 (5)							
0.1(104)	0.3 (3)						0.5 (5)							
0.15(154)							0.5 (5)							
0.22(224)			0.5 (5)	0.5 (5)										
0.33(334)			0.5 (5)											
0.47(474)			0.5 (5)											
0.68(684)			0.5 (5)											
1.0(105)	0.5 (5)													
1.5(155)							0.5 (5)							
2.2(225)							0.5 (5)							
3.3(335)							0.85 (C)							
4.7(475)							0.85 (C)							
10(106)							0.85 (C)							

■:X7R(B) ■:X5R(A) ■:Y5V(F) ▨:COG(C) ▩:X6S(X) ■■:X7S(Y)

Product Line UP (Low ESL Capacitors)

Part Number	TC Code	Temperature Characteristics	Size L×W (mm)	Capacitance	Capacitance Tolerance	Rated Voltage (Vdc)	Thickness Max. (mm)
CLL5Y104MQ3NLN □	X7S(EIA)	±22%(-55~+125℃)	0.50×1.00	100nF	±20%	6.3	0.33
CL01B103KB5NLN □	X7R(EIA)	±15%(-55~+125℃)	0.80×1.60	10nF	±10%	50	0.55
CL12B103KB5NLN □	X7R(EIA)	±15%(-55~+125℃)	1.25×2.00	10nF	±10%	50	0.55
CL12B103KBCNLN □	X7R(EIA)	±15%(-55~+125℃)	1.25×2.00	10nF	±10%	50	1.00
CL01B153KB5NLN □	X7R(EIA)	±15%(-55~+125℃)	0.80×1.60	15nF	±10%	50	0.55
CL12B153KB5NLN □	X7R(EIA)	±15%(-55~+125℃)	1.25×2.00	15nF	±10%	50	0.55
CL12B153KBCNLN □	X7R(EIA)	±15%(-55~+125℃)	1.25×2.00	15nF	±10%	50	1.00
CL01B223KB5NLN □	X7R(EIA)	±15%(-55~+125℃)	0.80×1.60	22nF	±10%	50	0.55
CL12B223KB5NLN □	X7R(EIA)	±15%(-55~+125℃)	1.25×2.00	22nF	±10%	50	0.55
CL12B223KBCNLN □	X7R(EIA)	±15%(-55~+125℃)	1.25×2.00	22nF	±10%	50	1.00
CL12B333KB5NLN □	X7R(EIA)	±15%(-55~+125℃)	1.25×2.00	33nF	±10%	50	0.55
CL12B333KBCNLN □	X7R(EIA)	±15%(-55~+125℃)	1.25×2.00	33nF	±10%	50	1.00
CL12B473KBCNLN □	X7R(EIA)	±15%(-55~+125℃)	1.25×2.00	47nF	±10%	50	1.00
CL12B683KBCNLN □	X7R(EIA)	±15%(-55~+125℃)	1.25×2.00	68nF	±10%	50	1.00
CL12B104KBCNLN □	X7R(EIA)	±15%(-55~+125℃)	1.25×2.00	100nF	±10%	50	1.00
CL13B104KB5NLN □	X7R(EIA)	±15%(-55~+125℃)	1.60×3.20	100nF	±10%	50	0.55
CL01B333KA5NLN □	X7R(EIA)	±15%(-55~+125℃)	0.80×1.60	33nF	±10%	25	0.55
CL01B473KA5NLN □	X7R(EIA)	±15%(-55~+125℃)	0.80×1.60	47nF	±10%	25	0.55
CL12B473KA5NLN □	X7R(EIA)	±15%(-55~+125℃)	1.25×2.00	47nF	±10%	25	0.55
CL12B154KACNLN □	X7R(EIA)	±15%(-55~+125℃)	1.25×2.00	150nF	±10%	25	1.00
CL12B224KA5NLN □	X7R(EIA)	±15%(-55~+125℃)	1.25×2.00	220nF	±10%	25	0.55
CL12B224KACNLN □	X7R(EIA)	±15%(-55~+125℃)	1.25×2.00	220nF	±10%	25	1.00
CL01B683KO5NLN □	X7R(EIA)	±15%(-55~+125℃)	0.80×1.60	68nF	±10%	16	0.55
CL12B683KO5NLN □	X7R(EIA)	±15%(-55~+125℃)	1.25×2.00	68nF	±10%	16	0.55
CL01B104KO5NLN □	X7R(EIA)	±15%(-55~+125℃)	0.80×1.60	100nF	±10%	16	0.55
CL12B104KO5NLN □	X7R(EIA)	±15%(-55~+125℃)	1.25×2.00	100nF	±10%	16	0.55
CL12B154KO5NLN □	X7R(EIA)	±15%(-55~+125℃)	1.25×2.00	150nF	±10%	16	0.55
CL12B334KOCNLN □	X7R(EIA)	±15%(-55~+125℃)	1.25×2.00	330nF	±10%	16	1.00
CL01B154KP5NLN □	X7R(EIA)	±15%(-55~+125℃)	0.80×1.60	150nF	±10%	10	0.55
CL01B224KP5NLN □	X7R(EIA)	±15%(-55~+125℃)	0.80×1.60	220nF	±10%	10	0.55
CL12B334KP5NLN □	X7R(EIA)	±15%(-55~+125℃)	1.25×2.00	330nF	±10%	10	0.55
CL12B474KP5NLN □	X7R(EIA)	±15%(-55~+125℃)	1.25×2.00	470nF	±10%	10	0.55
CL12B474KPCNLN □	X7R(EIA)	±15%(-55~+125℃)	1.25×2.00	470nF	±10%	10	1.00
CL12B684KPCNLN □	X7R(EIA)	±15%(-55~+125℃)	1.25×2.00	680nF	±10%	10	1.00
CL12B105KPCNLN □	X7R(EIA)	±15%(-55~+125℃)	1.25×2.00	1.0uF	±10%	10	1.00
CL01Y105MR5NLN □	X7S(EIA)	±22%(-55~+125℃)	0.80×1.60	1.0uF	±20%	4.0	0.55
CL01A334KQ5NLN □	X5R(EIA)	±15%(-55~+85℃)	0.80×1.60	330nF	±10%	6.3	0.55
CL01A474KQ5NLN □	X5R(EIA)	±15%(-55~+85℃)	0.80×1.60	470nF	±10%	6.3	0.55
CL01A684KQ5NLN □	X5R(EIA)	±15%(-55~+85℃)	0.80×1.60	680nF	±10%	6.3	0.55
CL01A105KQ5NLN □	X5R(EIA)	±15%(-55~+85℃)	0.80×1.60	1.0uF	±10%	6.3	0.55
CL12A155KQCNLN □	X5R(EIA)	±15%(-55~+85℃)	1.25×2.00	1.5uF	±10%	6.3	1.00
CL12A225KQCNLN □	X5R(EIA)	±15%(-55~+85℃)	1.25×2.00	2.2uF	±10%	6.3	1.00
CL12A335KQCNLN □	X5R(EIA)	±15%(-55~+85℃)	1.25×2.00	3.3uF	±10%	6.3	1.00
CL12A475KQCNLN □	X5R(EIA)	±15%(-55~+85℃)	1.25×2.00	4.7uF	±10%	6.3	1.00
CL13A106KQFNLN □	X5R(EIA)	±15%(-55~+85℃)	1.60×3.20	10uF	±10%	6.3	1.4

※ □ mark means packaging code. If you want to learn the code or quantity in detail, please see p 59.

Cardboard Paper Tape(4mm)

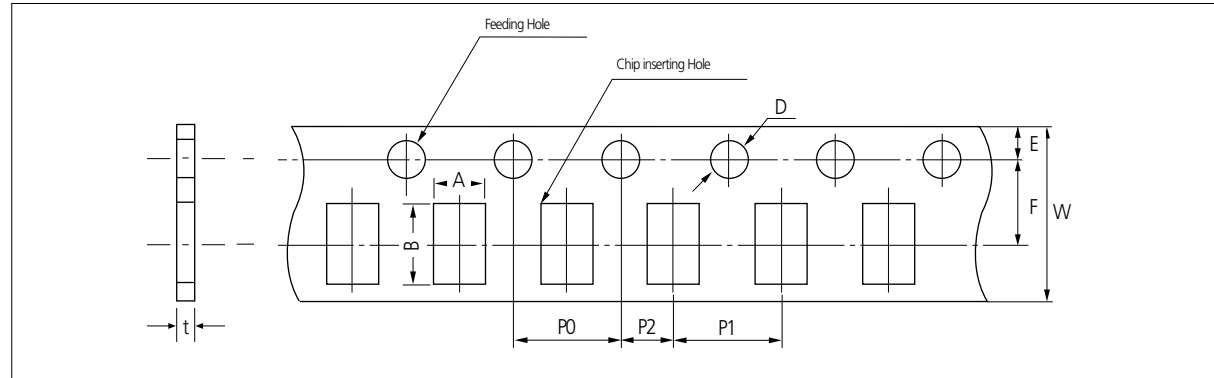

Unit: inch(mm)

Symbol Type	A	B	W	F	E	P1	P2	P0	D	t	
Dimension	0504 (1410)	1.3 ±0.2	1.7 ±0.2	8.0 ±0.3	3.5 ±0.05	1.75 ±0.1	4.0 ±0.1	2.0 ±0.05	4.0 ±0.1	Ø1.5 +0.1/-0	1.0 Below
	0603 0306 (1608) (0816)	1.1 ±0.2	1.9 ±0.2								
	0805 0508 (2012) (1220)	1.6 ±0.2	2.4 ±0.2								
	1206 0612 (3216) (1632)	2.0 ±0.2	3.6 ±0.2								

Cardboard Paper Tape(2mm)

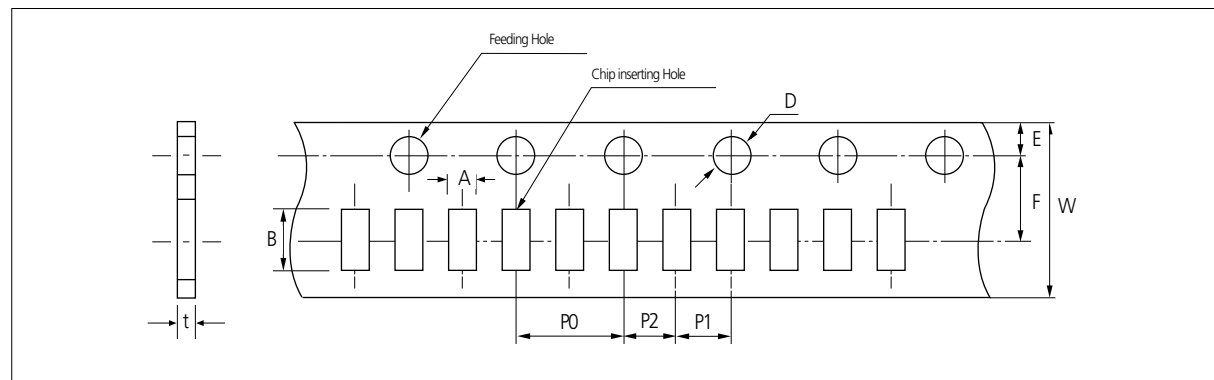

Unit: inch(mm)

Symbol Type	A	B	W	F	E	P1	P2	P0	D	t	
Dimension	0201 (0603)	0.38 ±0.03	0.68 ±0.03	8.0 ±0.3	3.5 ±0.05	1.75 ±0.1	2.0 ±0.05	2.0 ±0.05	4.0 ±0.1	Ø1.5 +0.1/-0.03	0.37 ±0.03
	0402 (1005)	0.62 ±0.04	1.12 ±0.04								0.6 ±0.05
											0.37 ±0.05

Embossed Plastic Tape

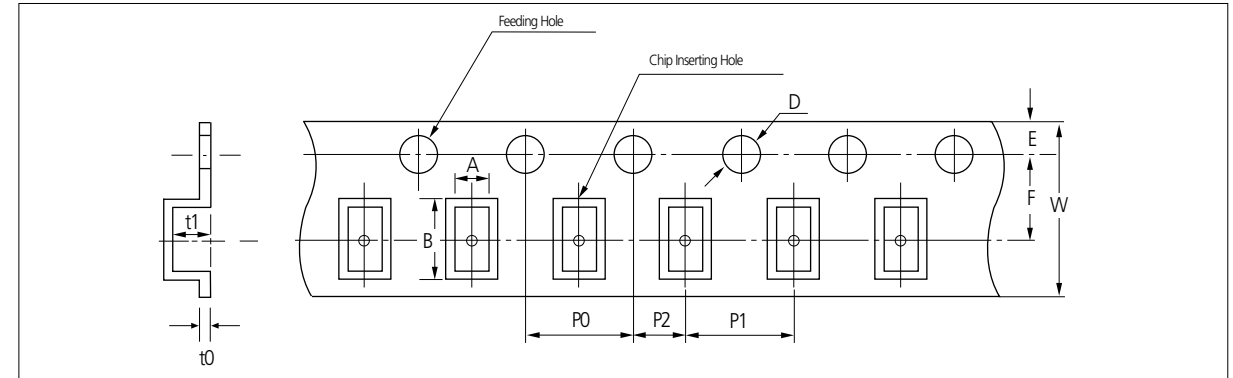

Unit: inch(mm)

Symbol Type	A	B	W	F	E	P1	P2	P0	D	t1	t0
Dimension	0603 (1608)	1.0 ±0.1	1.8 ±0.1	8.0 ±0.3	3.5 ±0.05	4.0 ±0.1	2.0 ±0.05	4.0 ±0.1	Ø1.5 +0.1/-0	2.5 max	0.6 BELOW
	0805 (2012)	1.45 ±0.2	2.3 ±0.2								
	1206 0612 (3216) (1632)	1.9 ±0.2	3.5 ±0.2								
	1210 (3225)	2.8 ±0.2	3.6 ±0.2								
	1808 (4520)	2.3 ±0.2	4.9 ±0.2								
	1812 (4532)	3.6 ±0.2	4.9 ±0.2								
	2220 (5750)	5.5 ±0.2	6.2 ±0.2								

Peeling off of Cover Tape

- 5 g.f ≤ Peel off force ≤ 70 g.f

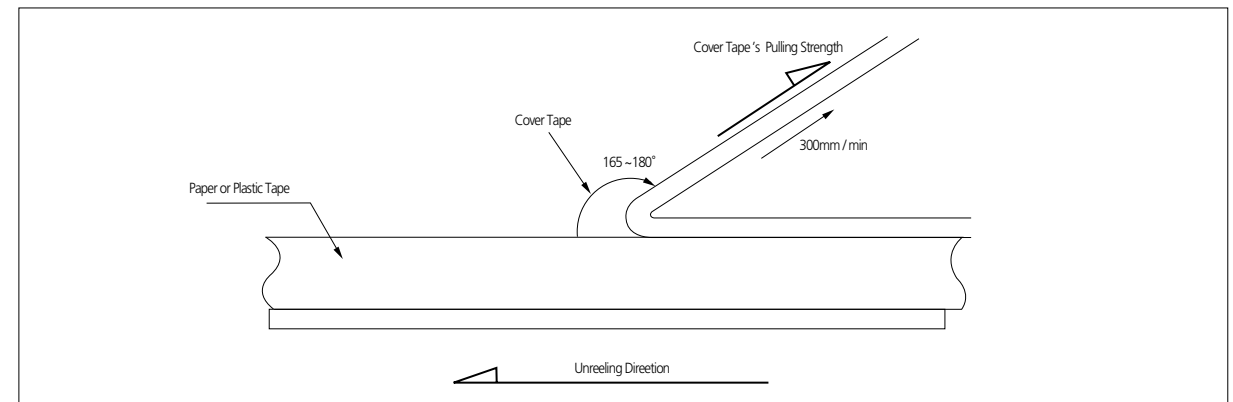

Taping Size

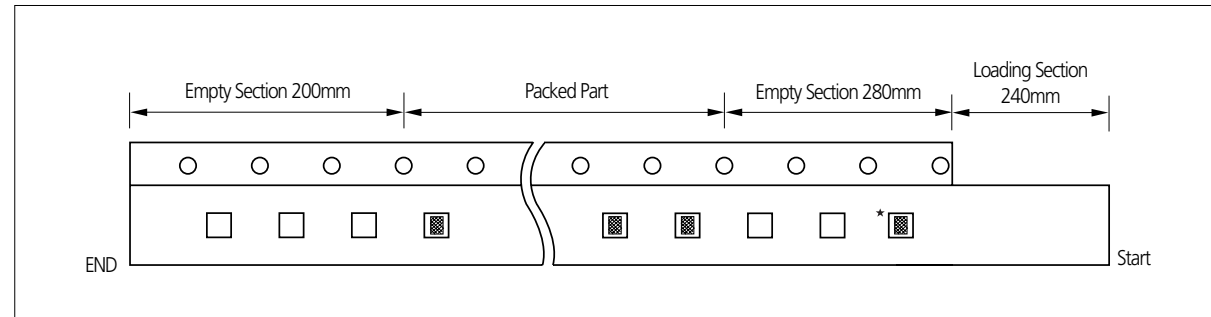

• The chip is only use for identifying the label and packaged products.
Please don't use the chip.

Unit: kpcs

Size	T code	Quantity & Packing Code								
		Paper Type					Plastic Type			
		C (7"reel)	H (7"reel)	O (10"reel)	D (13"reel)	L (13"reel)	E (7"reel)	G (7"reel)	F (13"reel)	S (7"reel)
0201(0603)	3	10	15	30	50	-	-	-	-	-
0402(1005)	3	10	-	30	50	-	-	-	-	-
	5	10	-	30	50	-	-	-	-	-
0504(1410)	8	4	-	10	10	15	-	-	-	-
0603(1608)	5	4	-	30	50	-	-	-	-	-
	8	4	-	10	10	15	-	-	-	-
0604(1610)	D	-	-	-	-	-	3	-	10	6
0805(2012)	A, C	4	-	10	10	15	-	-	-	-
	E, F, Q	-	-	-	-	-	2	3	10	6
1206(3216)	C	4	-	10	10	15	-	-	-	-
	E, F, P	-	-	-	-	-	2	3	10	6
	H	-	-	-	-	-	2	-	8	4
	9, D, C, O	-	-	-	-	-	2	-	10	-
1210(3225)	E, F, M	-	-	-	-	-	2	-	10	-
	H, T	-	-	-	-	-	2	-	8	4
	I, U	-	-	-	-	-	2	-	4	-
	J, V	-	-	-	-	-	1	-	4	-
	S	-	-	-	-	-	2	-	8	-
1808(4520)	F	-	-	-	-	-	2	-	-	-
1812(4532)	F, H, I	-	-	-	-	-	1	-	4	-
	L, J	-	-	-	-	-	-	-	2	-
2220(5750)	H, I, J	-	-	-	-	-	-	-	2	-

Reel Dimensions

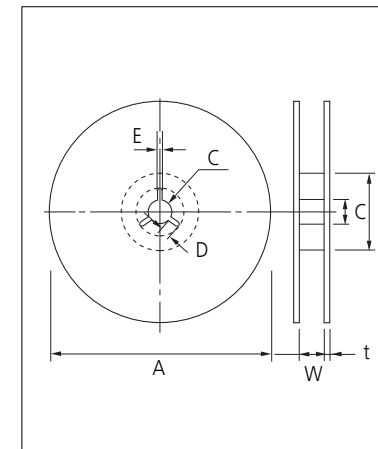

Unit: mm

Symbol	Tape Width	A	B	C	D
7" Reel	8mm	Ø180+0/-3	Ø80+1/-0	Ø13±0.3	4±0.2
	12mm	Ø180+0/-3	Ø80+1/-0	Ø13±0.3	4±0.2
10" Reel	8mm	Ø258+0/-3	Ø80+1/-0	Ø13±0.3	4±0.2
	12mm	Ø258+0/-3	Ø80+1/-0	Ø13±0.3	4±0.2
13" Reel	8mm	Ø330+2.0	Ø80±0.1	Ø13±0.3	4±0.2
	12mm	Ø330+2.0	Ø80±0.1	Ø13±0.3	4±0.2

Symbol	Tape Width	E	W	t
7" Reel	8mm	2.0±0.5	9±0.5	1.2±0.2
	12mm	2.0±0.5	13±0.5	1.2±0.2
10" Reel	8mm	2.0±0.5	9±0.5	1.8±0.2
	12mm	2.0±0.5	13±0.5	1.8±0.2
13" Reel	8mm	2.0±0.5	9±0.5	2.2±0.2
	12mm	2.0±0.5	13±0.5	2.2±0.2

Bulk Case Packaging

- Bulk case packaging can reduce the stock space and transportation costs.
- The bulk feeding system can increase the productivity.
- It can eliminate the components loss.

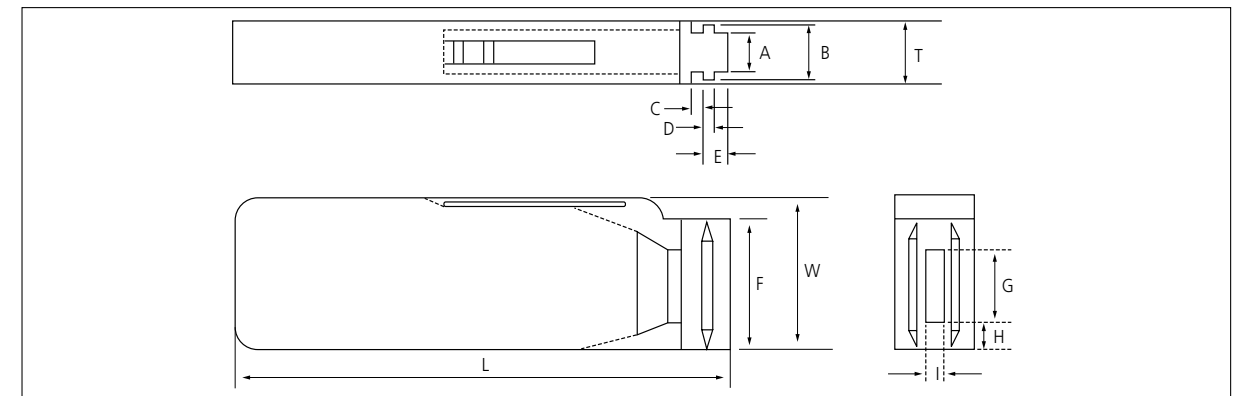

Unit: mm

Symbol	A	B	T	C	D	E
Dimension	6.8±0.1	8.8±0.1	12±0.1	1.5+0.1/-0	2+0/-0.1	3.0+0.2/-0

Symbol	F	W	G	H	L	I
Dimension	31.5+0.2/-0	36+0/-0.2	19±0.35	7±0.35	110±0.7	5±0.35

• QUANTITY

Unit: inch(mm) and pcs

Size	0402(1005)	0603(1608)	0805(2012)	
			T=0.65mm	T=0.85mm
Quantity	50,000	10,000 or 15,000	10,000	5,000 or 10,000

No	Item	Performance	Test Condition																											
1	Appearance	No abnormal exterior appearance	Visual Inspection through Microscope(× 10)																											
2	Insulation Resistance	10,000MΩ min. or 500MΩ · μF min. (or *100MΩ · μF) product whichever is smaller (Rated voltage ≤ 16V: 10,000MΩ min. or 100MΩ · μF min. product whichever is smaller)	Apply the rated voltage for 60~120 sec. *Rated voltage > 500V: Insulation Resistance shall be measured with 500 ± 50Vdc																											
3	Withstanding Voltage	No dielectric breakdown or mechanical breakdown	Apply the specified voltage* for 1~5 sec. Charge/Discharge current limit: 50mA max. *CLASS I (Rated Voltage < 100V): 300% of the rated Voltage CLASS II (Rated Voltage < 100V): 250% of the rated Voltage In the case of Vr ≥ 100V products, following condition should be applied. 100V ≤ Rated Voltage < 500V: 200% of the rated Voltage 500V ≤ Rated Voltage < 1000V: 150% of the rated Voltage Rated Voltage ≥ 1000V: 120% of the rated Voltage																											
4	Capacitance	CLASS I Within the specified tolerance	<table border="1"> <thead> <tr> <th>Capacitance</th> <th>Frequency</th> <th>Voltage</th> </tr> </thead> <tbody> <tr> <td>≤ 1,000pF</td> <td>1MHz ± 10%</td> <td rowspan="2">0.5 ~ 5 Vrms</td> </tr> <tr> <td>> 1,000pF</td> <td>1KHz ± 10%</td> </tr> </tbody> </table>	Capacitance	Frequency	Voltage	≤ 1,000pF	1MHz ± 10%	0.5 ~ 5 Vrms	> 1,000pF	1KHz ± 10%																			
		Capacitance	Frequency	Voltage																										
≤ 1,000pF	1MHz ± 10%	0.5 ~ 5 Vrms																												
> 1,000pF	1KHz ± 10%																													
CLASS II Within the specified tolerance	<table border="1"> <thead> <tr> <th>Capacitance</th> <th>Frequency</th> <th>Voltage</th> </tr> </thead> <tbody> <tr> <td>≤ 10μF</td> <td>1KHz ± 10%</td> <td>1.0 ± 0.2 Vrms</td> </tr> <tr> <td>> 10μF</td> <td>120Hz ± 20%</td> <td>0.5 ± 0.1 Vrms</td> </tr> <tr> <td>*</td> <td>1KHz ± 10%</td> <td>0.5 ± 0.1 Vrms</td> </tr> </tbody> </table>	Capacitance	Frequency	Voltage	≤ 10μF	1KHz ± 10%	1.0 ± 0.2 Vrms	> 10μF	120Hz ± 20%	0.5 ± 0.1 Vrms	*	1KHz ± 10%	0.5 ± 0.1 Vrms																	
Capacitance	Frequency	Voltage																												
≤ 10μF	1KHz ± 10%	1.0 ± 0.2 Vrms																												
> 10μF	120Hz ± 20%	0.5 ± 0.1 Vrms																												
*	1KHz ± 10%	0.5 ± 0.1 Vrms																												
5	Tanδ	CLASS I Capacitance ≥ 30pF : Q ≥ 1,000 < 30pF : Q ≥ 400 + 20 × C (C : Capacitance)	<table border="1"> <thead> <tr> <th>Capacitance</th> <th>Frequency</th> <th>Voltage</th> </tr> </thead> <tbody> <tr> <td>≤ 1,000pF</td> <td>1MHz ± 10%</td> <td rowspan="2">0.5 ~ 5 Vrms</td> </tr> <tr> <td>> 1,000pF</td> <td>1KHz ± 10%</td> </tr> </tbody> </table>	Capacitance	Frequency	Voltage	≤ 1,000pF	1MHz ± 10%	0.5 ~ 5 Vrms	> 1,000pF	1KHz ± 10%																			
		Capacitance	Frequency	Voltage																										
≤ 1,000pF	1MHz ± 10%	0.5 ~ 5 Vrms																												
> 1,000pF	1KHz ± 10%																													
CLASS II	<p>1. Characteristic: A(X5R)</p> <table border="1"> <thead> <tr> <th>Rated Voltage</th> <th>Spec</th> </tr> </thead> <tbody> <tr> <td>50V / 35V</td> <td>0.025 max / 0.05 max*</td> </tr> <tr> <td>25V</td> <td>0.025 max / 0.05 max* / 0.10 max*</td> </tr> <tr> <td>16V</td> <td>0.035 max / 0.05 max* / 0.10 max*</td> </tr> <tr> <td>≤ 10V</td> <td>0.05 max / 0.10 max*</td> </tr> </tbody> </table> <p>2. Characteristic: B(X7R), X(X6S), Y(X7S)</p> <table border="1"> <thead> <tr> <th>Rated Voltage</th> <th>Spec</th> </tr> </thead> <tbody> <tr> <td>50V / 35V / 25V</td> <td>0.025 max / 0.05 max* / 0.10 max*</td> </tr> <tr> <td>16V</td> <td>0.035 max / 0.10 max*</td> </tr> <tr> <td>≤ 10V</td> <td>0.05 max / 0.10 max*</td> </tr> </tbody> </table> <p>3. Characteristic: F(Y5V)</p> <table border="1"> <thead> <tr> <th>Rated Voltage</th> <th>Spec</th> </tr> </thead> <tbody> <tr> <td>50V / 35V / 25V</td> <td>0.05 max / 0.07 max* / 0.09 max*</td> </tr> <tr> <td>16V</td> <td>0.07 max / 0.09 max* / 0.125 max*</td> </tr> <tr> <td>10V</td> <td>0.125 max / 0.16 max*</td> </tr> <tr> <td>≤ 6.3V</td> <td>0.16 max</td> </tr> </tbody> </table>	Rated Voltage	Spec	50V / 35V	0.025 max / 0.05 max*	25V	0.025 max / 0.05 max* / 0.10 max*	16V	0.035 max / 0.05 max* / 0.10 max*	≤ 10V	0.05 max / 0.10 max*	Rated Voltage	Spec	50V / 35V / 25V	0.025 max / 0.05 max* / 0.10 max*	16V	0.035 max / 0.10 max*	≤ 10V	0.05 max / 0.10 max*	Rated Voltage	Spec	50V / 35V / 25V	0.05 max / 0.07 max* / 0.09 max*	16V	0.07 max / 0.09 max* / 0.125 max*	10V	0.125 max / 0.16 max*	≤ 6.3V	0.16 max	You can check the specification at the web site or contact sales people for each product with mark*
Rated Voltage	Spec																													
50V / 35V	0.025 max / 0.05 max*																													
25V	0.025 max / 0.05 max* / 0.10 max*																													
16V	0.035 max / 0.05 max* / 0.10 max*																													
≤ 10V	0.05 max / 0.10 max*																													
Rated Voltage	Spec																													
50V / 35V / 25V	0.025 max / 0.05 max* / 0.10 max*																													
16V	0.035 max / 0.10 max*																													
≤ 10V	0.05 max / 0.10 max*																													
Rated Voltage	Spec																													
50V / 35V / 25V	0.05 max / 0.07 max* / 0.09 max*																													
16V	0.07 max / 0.09 max* / 0.125 max*																													
10V	0.125 max / 0.16 max*																													
≤ 6.3V	0.16 max																													

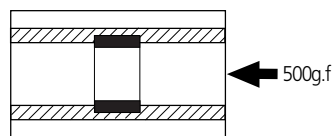
No	Item	Performance	Test Condition																			
6	Temperature Characteristics of Capacitance	CLASS I	<table border="1"> <thead> <tr> <th>Characteristic</th> <th>Temp. Coefficient (PPM/°C)</th> </tr> </thead> <tbody> <tr> <td>C</td> <td>0 ± 30</td> </tr> <tr> <td>P</td> <td>-150 ± 60</td> </tr> <tr> <td>R</td> <td>-220 ± 60</td> </tr> <tr> <td>S</td> <td>-330 ± 60</td> </tr> <tr> <td>T</td> <td>-470 ± 60</td> </tr> <tr> <td>U</td> <td>-750 ± 120</td> </tr> <tr> <td>S</td> <td>+350 ~ -1000</td> </tr> </tbody> </table>	Characteristic	Temp. Coefficient (PPM/°C)	C	0 ± 30	P	-150 ± 60	R	-220 ± 60	S	-330 ± 60	T	-470 ± 60	U	-750 ± 120	S	+350 ~ -1000	Capacitance shall be measured by the steps shown in the following table.		
		Characteristic	Temp. Coefficient (PPM/°C)																			
C	0 ± 30																					
P	-150 ± 60																					
R	-220 ± 60																					
S	-330 ± 60																					
T	-470 ± 60																					
U	-750 ± 120																					
S	+350 ~ -1000																					
CLASS II	<table border="1"> <thead> <tr> <th>Characteristic</th> <th>Capacitance Change (%) with No bias</th> </tr> </thead> <tbody> <tr> <td>A(X5R) / B(X7R)</td> <td>± 15%</td> </tr> <tr> <td>X(X6S), Y(X7S)</td> <td>± 22%</td> </tr> <tr> <td>F(Y5V)</td> <td>+22% ~ -82%</td> </tr> </tbody> </table>	Characteristic	Capacitance Change (%) with No bias	A(X5R) / B(X7R)	± 15%	X(X6S), Y(X7S)	± 22%	F(Y5V)	+22% ~ -82%	<table border="1"> <thead> <tr> <th>Step</th> <th>Temperature(°C)</th> </tr> </thead> <tbody> <tr> <td>1</td> <td>25 ± 2</td> </tr> <tr> <td>2</td> <td>Min. Operating Temp. ± 2</td> </tr> <tr> <td>3</td> <td>25 ± 2</td> </tr> <tr> <td>4</td> <td>Max. Operating Temp. ± 2</td> </tr> <tr> <td>5</td> <td></td> </tr> </tbody> </table> <p>(1) CLASS I Temperature Coefficient shall be calculated from the formula as below Temp. Coefficient = $\frac{C2 - C1}{C1 \times \Delta T} \times 10^6$ [ppm/°C] C1: Capacitance at step 3 C2: Capacitance at 85°C ΔT: 60°C (= 85°C - 25°C)</p> <p>(2) CLASS II Capacitance Change shall be calculated from the formula as below ΔC = $\frac{C2 - C1}{C1} \times 100$ (%) C1: Capacitance at step 3 C2: Capacitance at step 2 or 4</p>	Step	Temperature(°C)	1	25 ± 2	2	Min. Operating Temp. ± 2	3	25 ± 2	4	Max. Operating Temp. ± 2	5	
Characteristic	Capacitance Change (%) with No bias																					
A(X5R) / B(X7R)	± 15%																					
X(X6S), Y(X7S)	± 22%																					
F(Y5V)	+22% ~ -82%																					
Step	Temperature(°C)																					
1	25 ± 2																					
2	Min. Operating Temp. ± 2																					
3	25 ± 2																					
4	Max. Operating Temp. ± 2																					
5																						
7	Adhesive Strength of Termination	No indication of peeling shall occur on the terminal electrode	Apply 500g.f* pressure for 10 ± 1 sec. *200g.f for 0201 																			
8	Bending Strength	Appearance	No indication of peeling shall occur																			
		Capacitance	<table border="1"> <thead> <tr> <th>Characteristic</th> <th>Capacitance Change</th> </tr> </thead> <tbody> <tr> <td>CLASS I</td> <td>± 5% or ± 0.5 pF</td> </tr> <tr> <td>CLASS II</td> <td>A(X5R), B(X7R), X(X6S) ± 12.5% F(Y5V) ± 30%</td> </tr> </tbody> </table>	Characteristic	Capacitance Change	CLASS I	± 5% or ± 0.5 pF	CLASS II	A(X5R), B(X7R), X(X6S) ± 12.5% F(Y5V) ± 30%													
Characteristic	Capacitance Change																					
CLASS I	± 5% or ± 0.5 pF																					
CLASS II	A(X5R), B(X7R), X(X6S) ± 12.5% F(Y5V) ± 30%																					
9	Solderability	More than 75% of the terminal surface is to be soldered newly, so metal part does not come out or dissolve	<table border="1"> <thead> <tr> <th>Solder</th> <th>Sr-3Ag-0.5Cu</th> <th>63Sn-37Pb</th> </tr> </thead> <tbody> <tr> <td>Solder Temp.</td> <td>245 ± 5°C</td> <td>235 ± 5°C</td> </tr> <tr> <td>Flux</td> <td colspan="2">RMA Type</td> </tr> <tr> <td>Dip time</td> <td>3 ± 0.3 sec.</td> <td>5 ± 0.5 sec.</td> </tr> <tr> <td>Pre-heating</td> <td colspan="2">at 80~120°C for 10~30 sec.</td> </tr> </tbody> </table>	Solder	Sr-3Ag-0.5Cu	63Sn-37Pb	Solder Temp.	245 ± 5°C	235 ± 5°C	Flux	RMA Type		Dip time	3 ± 0.3 sec.	5 ± 0.5 sec.	Pre-heating	at 80~120°C for 10~30 sec.					
		Solder	Sr-3Ag-0.5Cu	63Sn-37Pb																		
Solder Temp.	245 ± 5°C	235 ± 5°C																				
Flux	RMA Type																					
Dip time	3 ± 0.3 sec.	5 ± 0.5 sec.																				
Pre-heating	at 80~120°C for 10~30 sec.																					
10	Resistance to Soldering Heat	Appearance	No mechanical damage shall occur																			
		Capacitance	<table border="1"> <thead> <tr> <th>Characteristic</th> <th>Capacitance Change</th> </tr> </thead> <tbody> <tr> <td>CLASS I</td> <td>± 2.5% or ± 0.25 pF whichever is larger</td> </tr> <tr> <td>CLASS II</td> <td>A(X5R), B(X7R) ± 7.5% X(X6S), Y(X7S) ± 7.5% F(Y5V) ± 20%</td> </tr> </tbody> </table>	Characteristic	Capacitance Change	CLASS I	± 2.5% or ± 0.25 pF whichever is larger	CLASS II	A(X5R), B(X7R) ± 7.5% X(X6S), Y(X7S) ± 7.5% F(Y5V) ± 20%													
Characteristic	Capacitance Change																					
CLASS I	± 2.5% or ± 0.25 pF whichever is larger																					
CLASS II	A(X5R), B(X7R) ± 7.5% X(X6S), Y(X7S) ± 7.5% F(Y5V) ± 20%																					
Q (CLASS I)	Within the specified initial value	Solder temperature: 270 ± 5°C DIP TIME: 10 ± 1 sec. Each termination shall be fully immersed and preheated as below: <table border="1"> <thead> <tr> <th>Step</th> <th>Temperature(°C)</th> <th>Time (sec.)</th> </tr> </thead> <tbody> <tr> <td>1</td> <td>80~100</td> <td>60</td> </tr> <tr> <td>2</td> <td>150~180</td> <td>60</td> </tr> </tbody> </table> Leave the capacitor in ambient condition for specified time* before measurement *24 ± 2 hours(CLASS I) 24 ± 2 hours(CLASS II)	Step	Temperature(°C)	Time (sec.)	1	80~100	60	2	150~180	60											
Step	Temperature(°C)		Time (sec.)																			
1	80~100		60																			
2	150~180		60																			
Tanδ (CLASS II)	Within the specified initial value																					
Insulation resistance	Within the specified initial value																					
Withstanding voltage	Within the specified initial value																					

No	Item	Performance	Test Condition	
11	Vibration Test	Appearance	No mechanical damage shall occur	
		Capacitance	Characteristic	Capacitance Change
			CLASS I	±2.5% or ± 0.25 pF whichever is larger
			CLASS II	A(X5R), B(X7R) ±5% X(X6S), Y(X7S) ±10% F(Y5V) ±20%
		Q (CLASS I)	Within the specified initial value	The capacitor shall be subjected to a harmonic motion having a total amplitude of 1.5mm changing frequency from 10Hz to 55Hz and back to 10Hz in about 1 min. Repeat this for 2hours each in 3 mutually perpendicular directions.
		Tanδ (CLASS II)	Within the specified initial value	
Insulation resistance	Within the specified initial value			
12	Humidity (Steady state)	Appearance	No mechanical damage shall occur	
		Capacitance	Characteristic	Capacitance Change
			CLASS I	±5% or ± 0.5 pF whichever is larger
			CLASS II	A(X5R), B(X7R), X(X6S), Y(X7S) ±12.5% F(Y5V) ±30%
		Q (CLASS I)	Capacitance ≥ 30pF : Q ≥ 350 10 ≤ Capacitance < 30pF : Q ≥ 275+2.5 × C Capacitance < 10pF : Q ≥ 200+10 × C (C: Capacitance)	Temperature: 40±2°C Humidity: 90~95% RH Duration Time: 500+12/0 Hr. Leave the capacitor in ambient condition for specified time* before measurement *24 ± 2 hours(CLASS I) 24 ± 2 hours(CLASS II)
		Tanδ (CLASS II)	1.Characteristic: A(X5R) 0.05 max / 0.075 max* (35V / 50V) 0.05 max / 0.075 max* / 0.125 max*(16V / 25V) 0.075 max / 0.125 max* (≤ 10V) 2.Characteristic: B(X7R), X(X6S) 0.05 max / 0.125 max* (16V / 25V / 35V / 50V) 0.075 max / 0.125 max* (≤ 10V) 3.Characteristic: F(Y5V) 0.09 max (50V) 0.09 max / 0.125 max* (25V / 35V) 0.09 max / 0.125 max* / 0.16 max* (16V) 0.16 max / 0.195 max* (10V) 0.195 max (4V / 6.3V)	
Insulation resistance	1,000MΩ min. or 50MΩ · μF min. product whichever is smaller / 25MΩ · μF or over*			
13	Moisture Resistance	Appearance	No mechanical damage shall occur	
		Capacitance	Characteristic	Capacitance Change
			CLASS I	±7.5% or ± 0.75pF whichever is larger
			CLASS II	A(X5R), B(X7R), X(X6S), Y(X7S) ±12.5% F(Y5V) ±30%
		Q (CLASS I)	Capacitance ≥ 30pF : Q ≥ 200 < 30pF : Q ≥ 100+10/3 × C (C: Capacitance)	Applied Voltage: rated voltage Temperature: 40±2°C Humidity: 90~95% RH Duration Time: 500+12/0 Hr. Charge/Discharge Current: 50mA max. Perform the initial measurement according to Note1. Perform the final measurement according to Note2.
		Tanδ (CLASS II)	1.Capacitance: A(X5R) 0.05 max / 0.075 max* (35V / 50V) 0.05 max / 0.075 max* / 0.125 max*(16V / 25V) 0.075 max / 0.125 max* (≤ 10V) 2.Capacitance: B(X7R), X(X6S) 0.05 max / 0.125 max* (16V / 25V / 35V / 50V) 0.075 max / 0.125 max* (≤ 10V) 3.Capacitance: F(Y5V) 0.09 max (50V) 0.09 max / 0.125 max* (25V / 35V) 0.09 max / 0.125 max* / 0.16 max* (16V) 0.16 max / 0.195 max* (10V) 0.195 max (4V / 6.3V)	
Insulation resistance	500MΩ min. or 25MΩ · μF min. product whichever is smaller / 12.5MΩ · μF or over*			
You can check the specification at the web site or contact sales people for each product with mark*				

No	Item	Performance	Test Condition																
14	High Temperature Resistance	Appearance	No mechanical damage shall occur																
		Capacitance	Characteristic	Capacitance Change															
			CLASS I	±3% or ± 0.3 pF whichever is larger															
			CLASS II	A(X5R), B(X7R) ±12.5% X(X6S), Y(X7S) ±30% F(Y5V) ±30%															
		Q (CLASS I)	Capacitance ≥ 30pF : Q ≥ 350 10 ≤ Capacitance < 30pF : Q ≥ 275+2.5 × C Capacitance < 10pF : Q ≥ 200+10 × C (C: Capacitance)	Applied Voltage: 200%* of the rated voltage Temperature: max. operating temperature Duration Time: 1000+48/0 Hr. Charge/Discharge Current: 50mA max. Rated Voltage < 250V: 200% of the rated Voltage 250V ≤ Vr < 500V: 150% of the rated Voltage Tip & Ring(250V): 110% of the rated Voltage 500V ≤ rated voltage < 1000V: 120% of the rated Voltage 1000V ≤ rated voltage ≤ 3000V: 100% of the rated Voltage * : 150% / 100% of the rated Voltage Perform the initial measurement according to Note1 for class II Perform the final measurement according to Note2.															
		Tanδ (CLASS II)	1.Capacitance: A(X5R) 0.05 max / 0.075 max* (35V / 50V) 0.05 max / 0.075 max* / 0.125 max*(16V / 25V) 0.075 max / 0.125 max* (≤ 10V) 2.Capacitance: B(X7R), X(X6S) 0.05 max / 0.125 max* (16V / 25V / 35V / 50V) 0.075 max / 0.125 max* (≤ 10V) 3.Capacitance: F(Y5V) 0.09 max (50V) 0.09 max / 0.125 max* (25V / 35V) 0.09 max / 0.125 max* / 0.16 max* (16V) 0.16 max / 0.195 max* (10V) 0.195 max (4V / 6.3V)																
Insulation resistance	1,000MΩ min. or 50MΩ · μF min. product whichever is smaller / 25MΩ · μF or over*																		
15	Temperature Cycle	Appearance	No mechanical damage shall occur																
		Capacitance	Characteristic	Capacitance Change															
			CLASS I	±2.5% or ± 0.25pF whichever is larger															
			CLASS II	A(X5R), B(X7R) ±7.5% X(X6S), Y(X7S) ±15% F(Y5V) ±20%															
		Q (CLASS I)	Within the specified initial value	Capacitor shall be subjected to 5 cycles. Condition for 1 cycle: <table border="1"> <thead> <tr> <th>Step</th> <th>Temperature(°C)</th> <th>Time(min.)</th> </tr> </thead> <tbody> <tr> <td>1</td> <td>min. operating temperature +0/-3</td> <td>30</td> </tr> <tr> <td>2</td> <td>25</td> <td>2~3</td> </tr> <tr> <td>3</td> <td>max. operating temperature +0/-3</td> <td>30</td> </tr> <tr> <td>4</td> <td>25</td> <td>2~3</td> </tr> </tbody> </table> Leave the capacitor in ambient condition for specified time* before measurement *24 ± 2 hours(CLASS I) 24 ± 2 hours(CLASS II)	Step	Temperature(°C)	Time(min.)	1	min. operating temperature +0/-3	30	2	25	2~3	3	max. operating temperature +0/-3	30	4	25	2~3
		Step	Temperature(°C)		Time(min.)														
1	min. operating temperature +0/-3	30																	
2	25	2~3																	
3	max. operating temperature +0/-3	30																	
4	25	2~3																	
Tanδ (CLASS II)	Within the specified initial value																		
Insulation resistance	Within the specified initial value																		

No	Recommended Soldering Method					
	Size inch(mm)	Temperature Characteristic	Capacitance	Condition		
				Flow	Reflow	
16	Recommended Soldering Method By Size & Capacitance	0201 (0603)	-	-	-	○
		0402 (1005)				
		0603(1608)	Class I	-	○	○
			Class II	$C < 1\mu F$	○	○
		0805 (2012)	Class II	$C \geq 1\mu F$	-	○
				Class I	-	○
			Class II	$C < 4.7\mu F$	○	○
				$C \geq 4.7\mu F$	-	○
		Array	-	-	-	○
			Class I	-	○	○
			Class II	$C < 10\mu F$	○	○
		1206 (3216)	Class II	$C \geq 10\mu F$	-	○
				Array	-	-
1210 (3225)	-	-	-	○		
1808 (4520)	-	-	-	○		
1812 (4532)	-	-	-	○		
2220 (5750)	-	-	-	○		

Note1. Initial Measurement For Class II

Perform the heat treatment at 150°C+0/-10°C for 1 hour. Then Leave the capacitor in ambient condition for 48±4 hours before measurement. Then perform the measurement.

Note2. Latter Measurement

- CLASS I**
Leave the capacitor in ambient condition for 24±2 hours before measurement. Then perform the measurement.
- CLASS II**
Perform the heat treatment at 150°C+0/-10°C for 1 hour. Then Leave the capacitor in ambient condition for 48±4 hours before measurement. Then perform the measurement.

Note3. All Size in Reliability Test Condition Section is "inch"

1.Storage of products

1-1. Storage Environment

Tape packing materials are designed to withstand long-term storage, but they will degrade more rapidly in the presence of high temperature or high humidity. Therefore, the products must be stored in an ambient 5~40°C with a relative humidity of 20~70%. Allowable storage period is within 6 months from the outgoing date of delivery.

1-2. Corrosive Gases

Since sulfur and chlorine may degrade the solderability of the end termination, it is important to store the capacitors in an environment free of these gases

1-3. Temperature Fluctuations

Since dew condensation may occur by the differences in temperature when the products are taken out of storage, it is important to maintain a temperature-controlled environment.

2.Design of Solder Land Pattern

When designing printed circuit boards, the shape and size of the solder lands must allow for the proper amount of solder on the capacitor. The amount of solder at the end terminations has a direct effect on the probability that the chip will crack. The greater amount of solder, the larger amount of stress on the chip, and the more likely that it will break. Use the following illustrations as guidelines for proper Solder land design.

Recommendation of solder Land Shape and Size

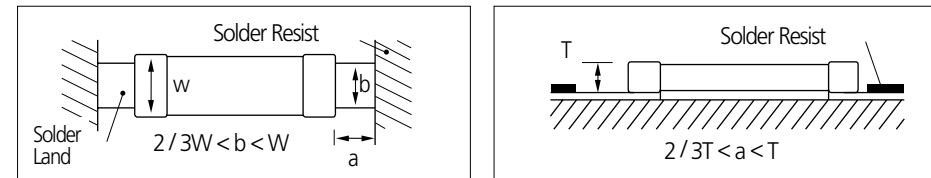

3.Adhesives

MLCCs generally require the use of an adhesive to position the chips to the circuit board prior to soldering.

3-1. Requirements for Adhesives

- They must have enough adhesion so that the chips will not fall off or move during the handling of the circuit board.
- They must maintain their adhesive strength when exposed to soldering temperatures.
- They should not spread or run when applied to the circuit board.
- They should have a long pot life.
- They should harden quickly.
- They should not corrode the circuit board or chip material.
- They should be a good insulator.
- They should be non-toxic, and not produce harmful gases, nor be harmful when touched.

3-2. Application Method

It is important to use the proper amount of adhesive. Too little will cause poor adhesion to the circuit board, and too much may strain the conductor pattern, thereby causing defective soldering. The following illustrations show the proper quantity of adhesive.

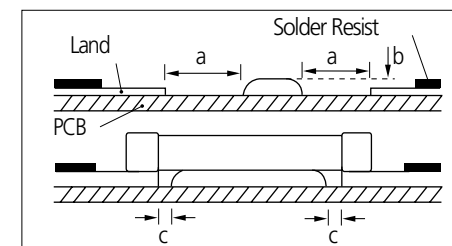

Type	21	31
a	0.2min	0.2min
b	70~100μm	70~100μm
c	>0	>0

Unit: mm

3-3. Adhesive hardening Characteristics

To prevent oxidation of the terminations, the adhesive must harden at 160 °C or less, within 2 minutes or less.

4. Mounting

4-1. Mounting Head Pressure

Excessive pressure will cause chip capacitors to crack. The pressure between nozzle and chip capacitor will be 300g maximum during mounting.

4-2. Bending Stress

Bending of printed circuit board by mounting head when double-sided circuit boards are used, chip capacitors first are mounted and soldered onto one side of the board. When the capacitors are mounted onto the other side, it is important to support the board as shown in the illustration. If the circuit board is not supported, it may bend, causing the already-installed capacitors to crack.

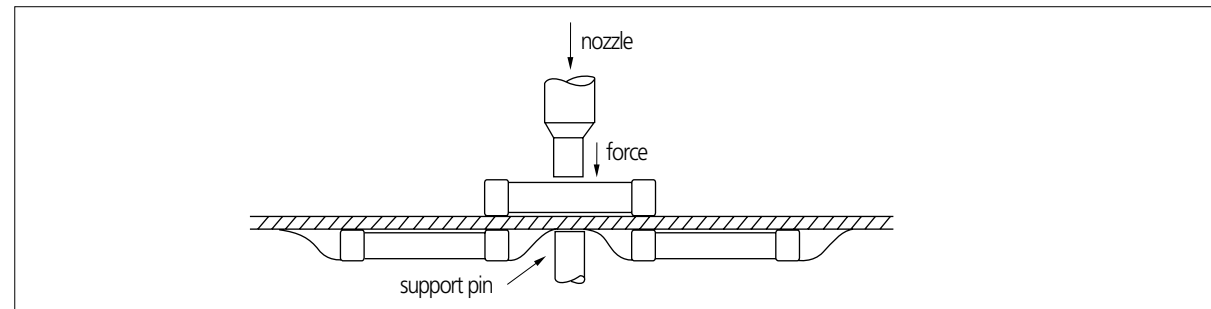

5. Flux

Although highly-activated flux gives better solderability, substances which increase activity may also degrade the insulation of the chip capacitors. To avoid such degradation, it is recommended that a mildly activated rosin flux (less than 0.2% chlorine) be used.

6. Soldering

Since a multilayer ceramic chip capacitor comes into direct contact with melted solder during soldering, it is exposed to potentially mechanical stress caused by the sudden temperature change. The capacitor may also be subject to silver migration, and to contamination by the flux. Because of these factors, soldering technique is critical.

6-1. Soldering Methods

Method	Classification	
Reflow soldering	· Overall heating	· Infrared rays · Hot plate · VPS (Vapor phase)
	· Local heating	· Air heater · Laser · Light beam
Flow Soldering	· Single wave · Double wave	

6-2. Soldering Profile

To avoid the crack problem by sudden temperature change, follow the temperature profile in the adjacent graph.

6-2-1 Pb-Free (Sn 100%) Plating

REFLOW SOLDERING

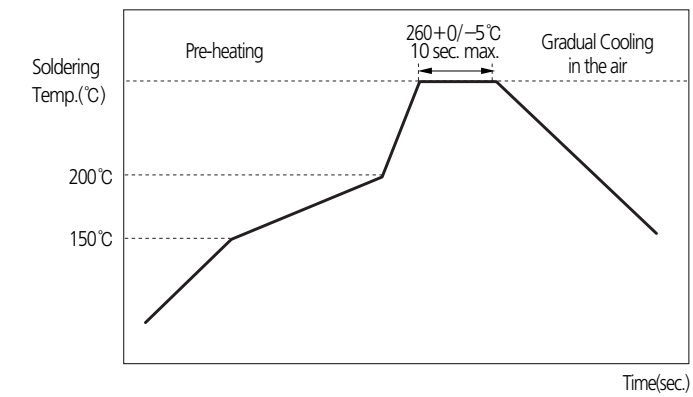

FLOW SOLDERING

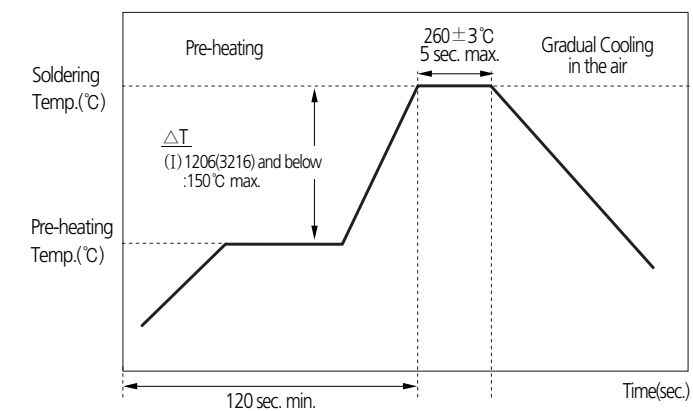

SOLDER IRON(Hand Soldering)

Variation of Temp.(°C)	Soldering Temp(°C)	Pre-heating Time(sec.)	Soldering Time(sec.)	Cooling Time(sec.)	Condition of Iron Facilities		
					Wattage	Tip Diameter	Soldering Time
ΔT≤130	300±10°C max.	≥ 60 sec.	≤ 4 sec.	-	20W max.	3mm max.	4 sec max.

6-3. Manual Soldering

Manual soldering can pose a great risk of creating thermal cracks in chip capacitors. The hot soldering iron tip comes into direct contact with the end terminations, and operator's carelessness may cause the tip of the soldering iron to come into direct contact with the ceramic body of the capacitor. Therefore the soldering iron must be handled carefully, and close attention must be paid to the selection of the soldering iron tip and to temperature control of the tip.

6-4. Amount of Solder

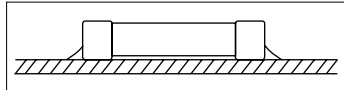
Too much Solder		Cracks tend to occur due to large stress.
Not enough solder		Weak holding force may cause bad connections or detaching of the capacitor

6-5. Cooling

Natural cooling using air is recommended. If the chips are dipped into solvent for cleaning, the temperature difference (ΔT) must be less than 100°C

6-6. Cleaning

If rosin flux is used, cleaning usually is unnecessary. When strongly activated flux is used, chlorine in the flux may dissolve into some types of cleaning fluids, thereby affecting the chip capacitors. This means that the cleaning fluid must be carefully selected, and should always be new.

7. Notes for Separating Multiple, Shared PC Boards

A multi-PC board is separated into many individual circuit boards after soldering has been completed. If the board is bent or distorted at the time of separation, cracks may occur in the chip capacitors. Carefully choose a separation method that minimizes the bending of the circuit board.

