

BA010-01 GMR Medical Sensors

Features:

- ⇒ Excellent Sensitivity to Applied Magnetic Fields
- ⇒ Wheatstone Bridge Analog Output
- ⇒ Wide Linear Range of Operation
- ⇒ Low Voltage Operation (<1V)
- ⇒ DC to >1MHz Frequency Response
- ⇒ Visually Inspected, Qualified for Implantable Medical Devices
- ⇒ Small Die Size

Applications:

- ⇒ Pacemakers
- ⇒ ICDs
- ⇒ Insulin Pumps

Description:

The BA010-01 sensors are GMR magnetometers specifically designed, inspected, tested, and qualified for implantable medical devices. They exhibit excellent magnetic performance including 98% linearity, a large output signal with applied magnetic fields, stable and linear temperature characteristics, and a pure ratiometric output.

The BA010-01 magnetic sensors are provided in die form, and delivered in wafer packs of 260 parts. They are background to a thickness of 200 microns, then diced and visually inspected on all six sides to Mil-883 standards. Each lot is qualified with a 40 part sample that is subjected to a 24 hour 150°C bake, repetitive thermal shocks, and a 7 day 125°C temperature soak. Wire bond pull tests are also performed for lot qualification purposes.

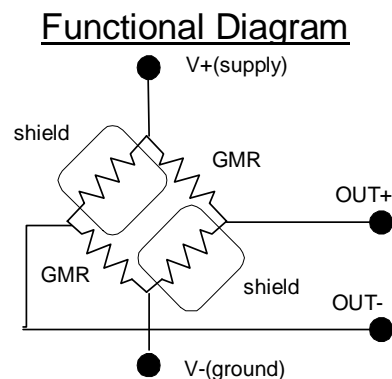

Magnetic, Resistance, and Size Characteristics:

Part Number	Saturation Field (Oe ¹)	Linear Range (Oe ¹)		Sensitivity (mV/V-Oe ¹)		Resistance (Ohms)	Die Size ³ (μm)	Die Thickness (μm)
		Min	Max	Min	Max			
BA010-01	15	1.5	10.5	3.0	4.2	5K ± 20%	436x3370	200 ± 25

Electrical and Temperature Characteristics:

Property	Min	Typical	Max	Unit
Input Voltage Range	<1 ⁴		± 25 ⁴	Volts
Operating Frequency	DC		> 1	MHz
Operating Temperature Range	-50		125	°C
Bridge Electrical Offset	-4		+4	mV/V
Signal Output at Max. Field		60		mV/V
Nonlinearity			2	% (unipolar) ⁵
Hysteresis			4	% (unipolar) ⁵
TCR		+0.14		% / °C ⁶
TCOI		+0.03		% / °C ⁶
TCOV		-0.1		% / °C ⁶
Off Axis Characteristic		Cos β ⁷		
ESD Tolerance		400		V pin to pin HBM

Notes:

- 1 Oersted (Oe) = 1 Gauss in air.
- Sensors can be provided in different sensitivities and geometries by special request.
- GMR BA Series sensors are pure ratiometric devices, meaning that they will operate properly at extremely low supply voltages. The output signal will be proportional to the supply voltage. Maximum voltage range is limited by the power dissipation in the package and the maximum operating temperature of the sensor.
- Unipolar operation means exposure to magnetic fields of one polarity, e.g., 0 to 30 Gauss, or -2 to -50 Gauss, but not -20 to +30 Gauss (bipolar operation). Bipolar operation will increase nonlinearity and hysteresis.
- TCR is resistance change with temperature with no applied field. TCOI is the output change with temperature using a constant current source to power the sensor. TCOV is the output change with temperature using a constant voltage source to power the sensor. See the graphs below.
- Beta (β) is any angle from the sensitive axis.

