

D/589A/3 September 1998

Provisional Information

Features and Applications

- Data Rates from 4kbps to 200kbps
- Full or Half Duplex Gaussian Filter and Data Recovery for Minimum Shift Keying (GMSK) Designs
- Selectable BT: (0.3 or 0.5)
- Low Power
 - 3.0V, 20kbps, 1.5mA typ.
 - 5.0V, 64kbps, 4.0mA typ.
- Low Current Non-DSP Solution
- Small TSSOP Packs fit PCMCIA/PC Cards
- Portable Wireless Data Applications
 - Cellular Digital Packet Data (CDPD)
 - Mobitex™ Mobile Data System
- Spread Spectrum Data Links
- GPS/Differential GPS Wireless Links
- Point-of-Sale Terminals
- Low Power Wireless Data Link for PCs, Laptops, and Printers

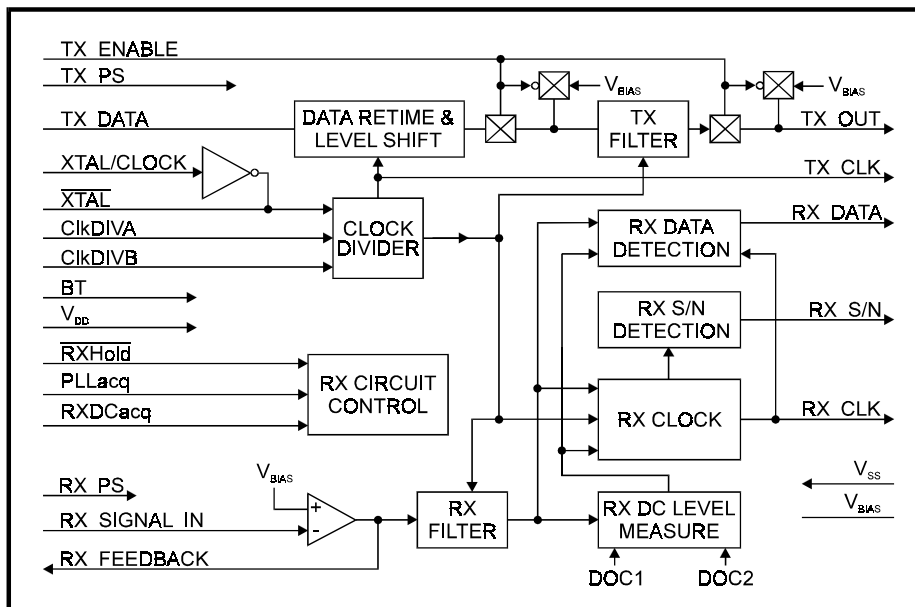

Brief Description

The CMX589A is a single-chip synchronous data pump/modem designed for Wireless Data Applications. Employing Gaussian filtering for Minimum shift Keying (GMSK) baseband modulation applications, the CMX589A features a wide range of available data rates from 4k to 200k bps. Data Rates and the choice of BT (0.3 or 0.5) are pin programmable to provide for different system requirements.

The Tx and Rx digital data interfaces are bit serial, synchronized to generated Tx and Rx data clocks. Separate Tx and Rx Powersave inputs allow full or half-duplex operation. Rx input levels can be set by suitable AC and DC level adjusting circuitry built with external components around an on-chip Rx Input Amplifier.

Acquisition, Lock, and Hold of Rx data signals are made easier and faster by the use of Rx Control Inputs to clamp, detect, and /or hold input data levels and can be set by the μ Processor as required. The Rx S/N output provides an indication of the quality of the received signal.

The CMX589A may be used with a 3.0V to 5.5V power supply and is available in the following packages: 24-pin TSSOP (CMX589AE2), 24-pin SSOP (CMX589AD5), 24-pin SOIC (CMX589AD2), and 24-pin PDIP (CMX589AP4).

Contents

Section	Page
Features and Applications	1
Brief Description	1
Block Diagram	2
2 Signal List	4
3 External Components	6
4 General Description	8
4.1 Clock Oscillator Divider.....	8
4.2 Receive	8
4.2.1 Rx Signal Path Description.....	8
4.2.2 Rx Circuit Control Modes.....	9
4.2.3 Rx Clock Extraction	10
4.2.4 Rx Data Extraction.....	10
4.2.6 Rx Signal Quality	12
4.3 Transmit	12
4.3.1 Tx Signal Path Description	12
4.4 Data Formats.....	15
4.5 Acquisition and Hold Modes	15
5 Application.....	16
5.1 Radio Channel Requirements.....	16
5.1.1 Bit Rate, BT, and Bandwidth	16
5.1.2 FM Modulator, Demodulator and IF.....	16
5.1.3 Two-Point Modulation.....	17
5.2 AC Coupling of Tx and Rx Signals.....	18
6 Performance Specifications.....	19
6.1 Electrical Specifications	19
6.1.1 Absolute Maximum Limits.....	19
6.1.2 Operating Limits	20
6.1.3 Operating Characteristics	21
6.2 Packages.....	23

Block Diagram

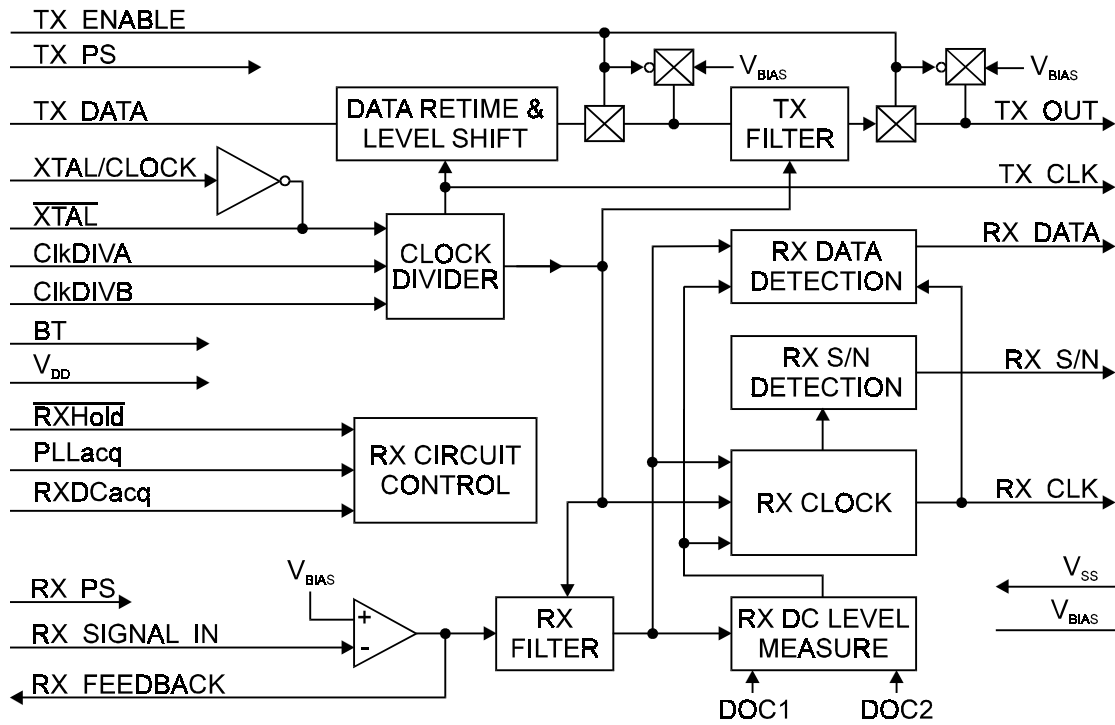

Figure 1: Block Diagram

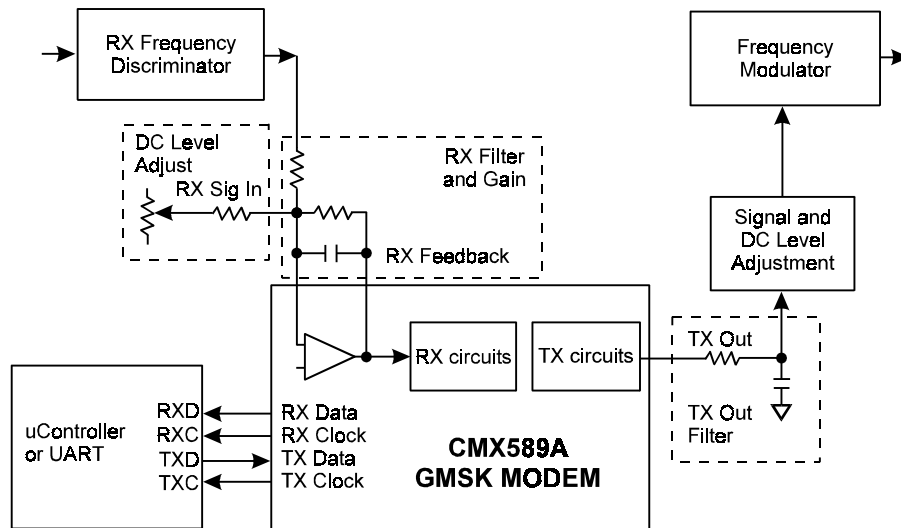

Figure 2: System Block Diagram

2 Signal List

Pin No. E2/D5/ D2/P4	Signal	Type	Description
1	XTALN	O/P	The output of the on-chip clock oscillator.
2	XTAL/CLOCK	I/P	The input to the on-chip Xtal oscillator. A Xtal, or externally derived clock (f_{XTAL}) pulse input should be connected here. If an externally generated clock is to be used, it should be connected to this pin and the XTALN pin left unconnected. Note: Operation without a suitable Xtal or clock input may cause device damage.
3	ClkDivA	I/P	Logic level inputs control the internal clock divider and therefore the transmit and receive data rate. See Table 4.
4	ClkDivB	I/P	Logic level inputs control the internal clock divider and therefore the transmit and receive data rate. See Table 4.
5	RxHOLDN	I/P	A logic '0' applied to this input will freeze the Clock Extraction and Level Measurement circuits unless they are in 'Acquire' mode.
6	RxDCacq	I/P	A logic '1' applied to this input will set the Rx Level Measurement circuitry to the 'Acquire' mode. See Table 6.
7	PLLacq	I/P	A logic '1' applied to this input will set the Rx Clock Extraction circuitry to the 'Acquire' mode. See Table 5.
8	Rx PSAVE	I/P	A logic '1' applied to this input will powersave all receive circuits except for Rx CLK output (which will continue at the set bit-rate) and cause the Rx Data and Rx S/N outputs to go to a logic '0'.
9	V _{BIAS}		The internal circuitry bias line, held at $V_{DD}/2$. This pin must be bypassed to V_{SS} by a capacitor mounted close to the pin.
10	Rx FB	O/P	Output of the Rx Input Amplifier.
11	Rx Signal In	I/P	Input to Rx input amplifier.
12	V _{SS}	power	Negative supply (GND).
13	DOC1		Connections to the Rx Level Measurement Circuitry. A capacitor should be connected from this pin to V_{SS} .
14	DOC2		Connections to the Rx Level Measurement Circuitry. A capacitor should be connected from this pin to V_{SS} .
15	BT		A logic level to select the modem BT (the ratio of the Tx Filter's -3dB frequency to the Bit-Rate). A logic '1' = BT of 0.5 and a logic '0' = BT of 0.3.

Pin No. E2/D5/ D2/P4	Signal	Type	Description
16	Tx Out	I/P	Gaussian filtered Tx output signal. In powersave mode the Tx Out pin is high impedance.
17	Tx Enable	I/P	A logic '1' applied to this input, enables the transmit data path, through the Tx Filter to the Tx Out pin. A logic '0' will place the Tx Out pin to V _{BIAS} via a high impedance.
18	Tx PSAVE	I/P	A logic '1' applied to this input will powersave all transmit circuits except for the Tx Clock.
19	Tx Data	I/P	The logic level input for the data to be transmitted. This data should be synchronous with Tx CLK.
20	Rx Data	I/P	A logic level output carrying the received data, synchronous with Rx CLK.
21	Rx CLK	I/P	A logic level clock output at the received data bit-rate.
22	Tx CLK	I/P	A logic level clock output at the transmit data bit-rate.
23	Rx S/N	O/P	A logic level output which may be used as an indication of the quality of the received signal.
24	V _{DD}	power	Positive supply. Levels and voltages within the device are dependent upon this supply. This pin should be bypassed to V _{SS} by a capacitor mounted close to the pin.

Table 1: Signal List

3 External Components

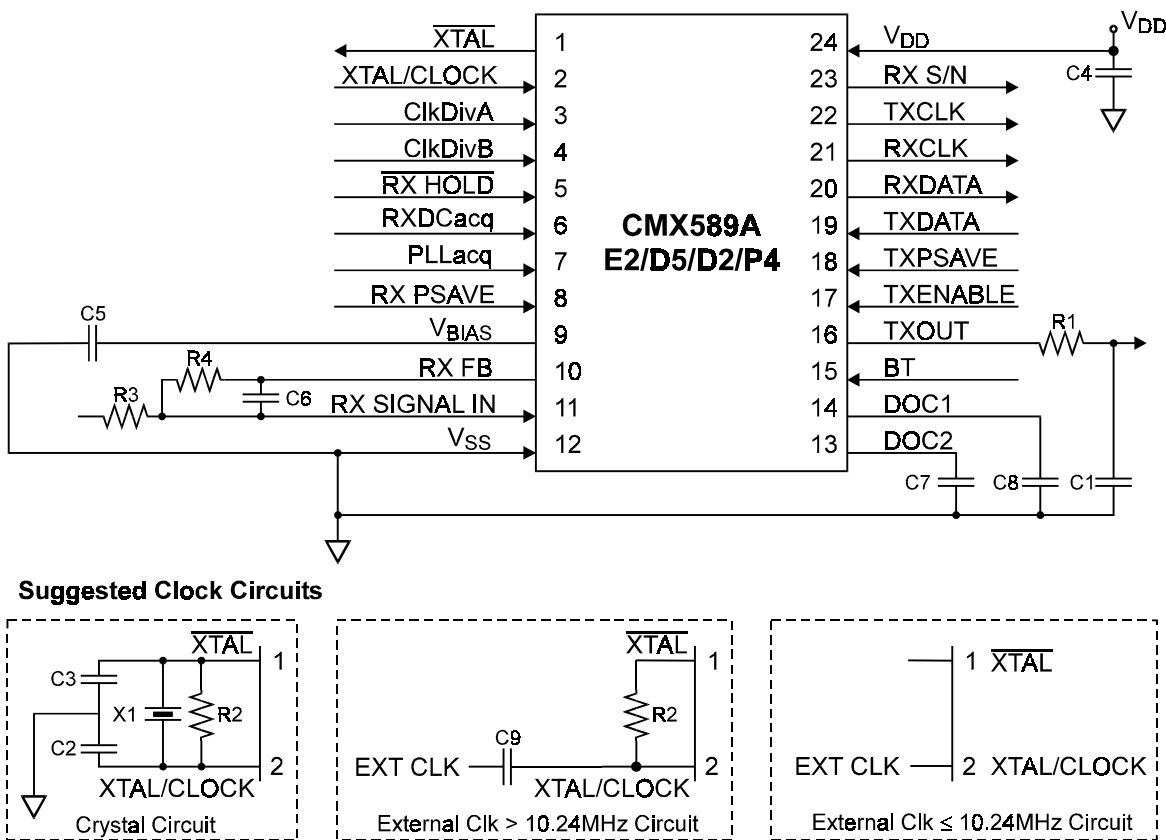

Figure 3: Recommended External Components

Component	Notes	Value	Tolerance
R1	1		±5%
R2		1.0MΩ	±10%
R3	2		±10%
R4	3		±10%
C1	1		±10%
C2	4		
C3	4		

Component	Notes	Value	Tolerance
C4		0.1μF	±20%
C5		1.0μF	±20%
C6	5		±20%
C7	6		
C8	6		
X1	8		

Table 2: Recommended External Components

Recommended External Component Notes:

- The RC network formed by R1 and C1 is required between the Tx Out pin and the input to the modulator. This network, which can form part of any DC level shifting and gain adjustment circuitry, forms an important part of the transmit signal filtering. The ground connection to the capacitor C1 should be positioned to give maximum attenuation of high-frequency noise into the modulator. The component values should be chosen so that the product of the resistance and the capacitance is:

For a BT of 0.3 $R1C1 = 0.34/\text{bit rate (bps)}$
 For a BT of 0.5 $R1C1 = 0.22/\text{bit rate (bps)}$

Data Rates (kbps)	BT = 0.3		BT = 0.5	
	R1	C1	R1	C1
4	120k Ω	680pF	120k Ω	470pF
4.8	100k Ω	680pF	100k Ω	470pF
8	91k Ω	470pF	120k Ω	220pF
9.6	91k Ω	390pF	47k Ω	470pF
16	47k Ω	470pF	91k Ω	150pF
19.2	100k Ω	180pF	91k Ω	120pF
32	47k Ω	220pF	47k Ω	150pF
38.4 *	47k Ω	180pF	47k Ω	120pF
64 *	56k Ω	100pF	51k Ω	68pF
80 *			39k Ω	68pF
128 *			82k Ω	22pF
144 *			68k Ω	22pF
160 *			62k Ω	22pF
176 *			56k Ω	22pF
192 *			51k Ω	22pF

* $V_{DD} \geq 4.5V$, external clock

Table 3: Data Rate vs. BT and Selected External Component Values

Note: In all cases, the value of R1 should not be less than 20.0k Ω , and that the calculated value of C1 includes calculated parasitic capacitance.

- R3, R4 and C6 form the gain components for the Rx Input signal. R3 should be chosen as required by the signal input level.
- For bit rate ≤ 64 kbps, R4 = 100k Ω . For bit rate > 64 kbps, R4 = 10k Ω .
- The values chosen for C2 and C3 (including stray capacitance), should be suitable for the applied V_{DD} and the frequency of X1.
As a guide: C2 = C3 = 33pF at 1.0MHz falling to 18pF at the maximum frequency.
At 3.0V, C2 = C3 = 33pF falling to 18pF at 5.0MHz the equivalent series resistance of X1 should be less than 2.0K Ω falling to 150 Ω at the maximum frequency. Stray capacitance on the Xtal/Clock circuit pins must be minimized.
- For bit rate ≤ 64 kbps, C6 = 22pF. For bit rate > 64 kbps, $C6 = \frac{1}{3 \times \text{bit rate} \times 2\pi \times 10k\Omega}$
e.g. for 128kbps, C6 = 41.1pF.
- C7 and C8 should both be .015 μ F for a data rate of 8kbps, and inversely proportional to the data rate for other data rates, e.g. 0.030 μ F at 4kbps, 1800pF at 64kbps, 680pF at 192kbps.
- The tolerance of C9 is not very critical because it primarily serves as a dc blocking capacitor.
- The CMX589A can operate correctly with the Xtal frequencies between 1.0MHz and 16.0MHz ($V_{DD} = 5.0V$) and 1.0MHz to 5.0MHz ($V_{DD} = 3.0V$). External clock frequencies up to 25.6MHz ($V_{DD} \geq 4.5V$) are also supported (See Table 4 for examples.) For best results, a crystal oscillator design should drive the clock inverter input with signal levels of at least 40% of V_{DD} , peak to peak. Tuning fork crystals generally cannot meet this requirement. To obtain crystal oscillator design assistance, consult your crystal manufacturer. Operation of this device without a Xtal or Clock input may cause device damage.

4 General Description

4.1 Clock Oscillator Divider

The Tx and (nominal) Rx data rates are determined by division of the frequency present at the XTALN pin as generated by the on-chip Xtal oscillator, with external components, or supplied from an external source.

The division ratio is controlled by the logic level inputs on ClkDivA and ClkDivB pins as shown in Table 4, together with an indication of how various standard data rates may be derived from common μ P Xtal frequencies.

$$\text{Data Rate} = \frac{\text{Xtal/Clk Frequency}}{\text{Division Ratio (ClkDiv A/B)}}$$

Inputs		Xtal/Clk Freq	Xtal/Clock Frequency (MHz)					
			24.576*	8.192	4.9152	4.096	2.4576	2.048
ClkDivA	ClkDivB	Data Rate	Data Rate (kbps)					
0	0	128	192*	64*	38.4*	32	19.2	16
0	1	256	96*	32	19.2	16	9.6	8
1	0	512	48*	16	9.6	8	4.8	4
1	1	1024	24*	8	4.8	4		

* $V_{DD} \geq 4.5V$, external clock

Table 4: Example Clock/Data Rates

Note: The device operation is not guaranteed above 200kbps or below 4kbps at the relevant supply voltage.

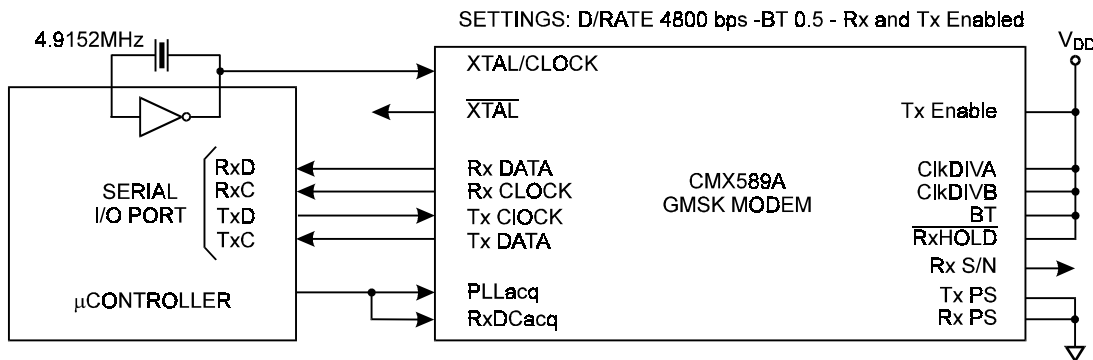

Figure 4: Minimum μ Controller System Connections

4.2 Receive

4.2.1 Rx Signal Path Description

The function of the Rx circuitry is to:

1. Set the incoming signal to a usable level.
2. Clean the signal by filtering.
3. Provide dc level thresholds for clock and data extraction.
4. Provide clock timing information for data extraction and external circuits.
5. Provide Rx data in a binary form.
6. Assess signal quality and provide Signal-to-Noise information.

The output of the radio receiver's Frequency Discriminator should be fed to the CMX589A's Rx Filter by a suitable gain and DC level adjusting circuit. This circuit can be built with external components around the on-chip Rx Input Amplifier. The gain should be set so that the signal level at the Rx Feedback pin is nominally 1V peak to peak (for $V_{DD}=5.0V$) centered around V_{BIAS} when receiving a continuous 1111000011110000.. data pattern.

Positive going signal excursions at Rx Feedback pin will produce a logic '0' at the Rx Data Output. Negative going excursions will produce a logic '1'.

The received signal is fed through the lowpass Rx Filter, which has a -3dB corner frequency of 0.56 times the data bit-rate, before being applied to the Level Measure and Clock and Data extraction blocks.

The Level Measuring block consists of two voltage detectors, one of which measures the amplitude of the positive parts of the received signal. The other measures the amplitude of the negative portions. (Positive refers to signal levels higher than $V_{DD}/2$, and negative to levels lower than $V_{DD}/2$.) External capacitors are used by these detectors, via the Doc1 and Doc2 pins, to form voltage 'hold' or 'integrator' circuits. These two levels are then used to establish the optimum DC level decision-thresholds for the Clock and Data extraction, depending upon the Rx signal amplitude and any DC offset.

4.2.2 Rx Circuit Control Modes

The operating characteristics of the Rx Level Measurement and Clock Extraction circuits are controlled, as shown in Table 6, by logic level inputs applied to the PLLacq, Rx HOLDN and RxDCacq pins to suit a particular application, or to cope with changing reception conditions, reference Figure 5.

In general, a data transmission will begin with a preamble, for example, 1100110011001100, to allow the receive modem to establish timing and level-lock as quickly as possible. After the Rx carrier has been detected, and during the time that the preamble is expected, the RxDCacq and PLLacq Inputs should be switched from a logic '0' to a logic '1' so that the Level Measuring and Clock Extraction modes are operated and sequenced as shown.

The Rx HOLDN input should normally be held at a logic '1' while data is being received, but may be driven to a logic '0' to freeze the Level Measuring Clock Extraction circuits during a fade. If a fade lasts for less than 200 bit periods, normal operation can be resumed by returning the Rx HOLDN input to a logic '1' at the end of the fade. For longer fades, it may be better to reset the Level Measuring circuits by placing the RxDCacq to a logic '1' for 10 to 20 bit periods.

Rx HOLDN has no effect on the Level Measuring circuits while RxDCacq is at a logic '1', and has no effect on the PLL while PLLacq is at a logic '1'.

A logic '0' on Rx HOLDN does not disable the Rx Clock output, and the Rx Data Extraction and S/N Detector circuits will continue to operate.

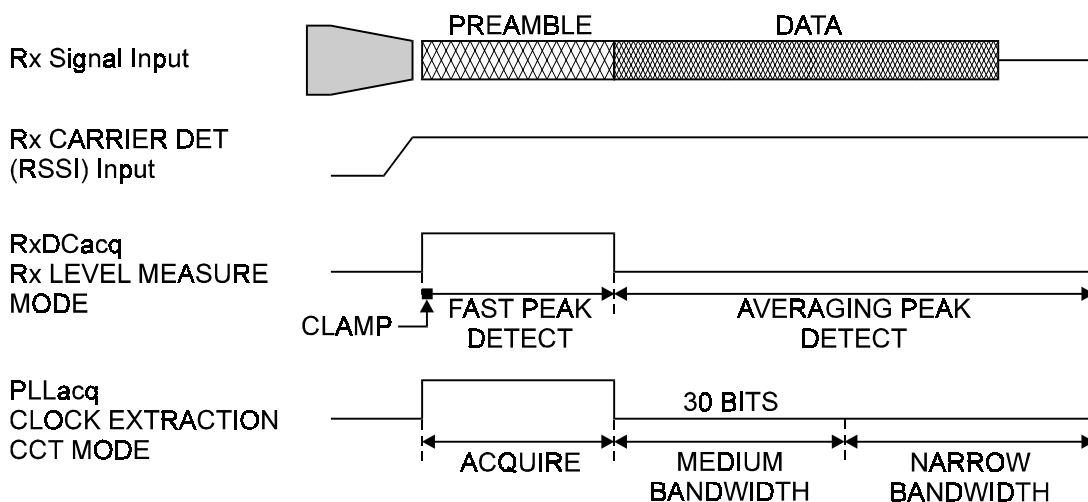

Figure 5: Rx Mode Control Diagram

PLLacq	Rx HOLDN	PLL Action	
1	1	Acquire	Sets the PLL bandwidth wide enough to allow a lock to the received signal in less than 8 zero crossings. This mode will operate as long as PLLacq is a logic "1".
1 to 0	1	Medium Bandwidth	The correction applied to the extracted clock is limited to a maximum of $\pm 1/16$ th bit-period for every two received zero-crossings. The PLL operates in this mode for a period of about 30 bits immediately following a 1 to 0 transition of the PLLacq input, provided that the Rx HOLDN input is a logic '1'.
0	1	Narrow Bandwidth	The correction applied to the extracted clock is limited to a maximum of $\pm 1/64$ th bit-period for every two received zero-crossings. The PLL operates in this mode whenever the Rx HOLDN Input is a logic '1' and PLLacq has been a logic '0' for at least 30 bit periods (after Medium Bandwidth operation for instance).
0	0	Hold	The PLL feedback loop is broken, allowing the Rx Clock to freewheel during signal fade periods.

Table 5: PLL Action Measurement Operational Modes

RxDCacq	Rx HOLDN	Rx Level Measure Action	
0 to 1	X	Clamp	Operates for one bit-time after a 0 to 1 transition of the RXDCacq input. The external capacitors are rapidly charged towards a voltage mid-way between the received signal input level and V_{BIAS} , with the charge time-constant being of the order of 0.5 bit-time.
1	X	Fast Peak Detect	The voltage detectors act as peak-detectors, one capacitor is used to capture the positive-going signal peaks of the Rx Filter output signal and the other capturing the negative-going peaks. The detectors operate in this mode whenever the RXDCacq input is at a logic '1', except for the initial 1-bit Clamp-mode time.
0	1	Averaging Peak Detect	Provides a slower but more accurate measurement of the signal peak amplitudes.
0	0	Hold	The capacitor charging circuits are disabled so that the outputs of the voltage detectors remain substantially at the last readings (discharging very slowly [time-constant approx. 2,000 bits] towards V_{BIAS}).

X = Do not care

Table 6: Rx Level Measurement Operational Modes

4.2.3 Rx Clock Extraction

Synchronized by a PLL circuit to zero-crossings of the incoming data, the Rx Clock Extraction circuitry controls the Rx Clock output. The Rx Clock is also used internally by the Data Extraction circuitry. The PLL parameters can be varied by the Rx Circuit Control inputs PLLacq and Rx HOLDN to operate in one of four PLL modes as described in Table 5 and Table 6.

4.2.4 Rx Data Extraction

The Rx Data Extraction circuit decides whether each received bit is a 1 or 0 by sampling the received signal, after filtering, and comparing the sample values to an adaptive threshold derived from the Level Measuring circuit. This threshold is adapted from bit to bit to compensate for intersymbol interference caused by the and limiting of the overall transmission path and the Gaussian premodulation filter. Extracted data is output from the Rx Data pin, and should be sampled externally on the rising edge of the Rx CLK.

4.2.5 Rx S/N Detection

The Rx S/N Detector system classifies the incoming zero-crossings as GOOD or BAD depending upon the time when each crossing actually occurs with respect to its expected time as determined by the Clock Extraction PLL. This information is then processed to provide a logic level output at the Rx S/N pin. A high level indicates a series of GOOD crossings; a low level indicates a BAD crossing.

By averaging this output, it is possible to derive a measure of the Signal-to-Noise-Ratio and hence the Bit-Error-Rate of the received signal.

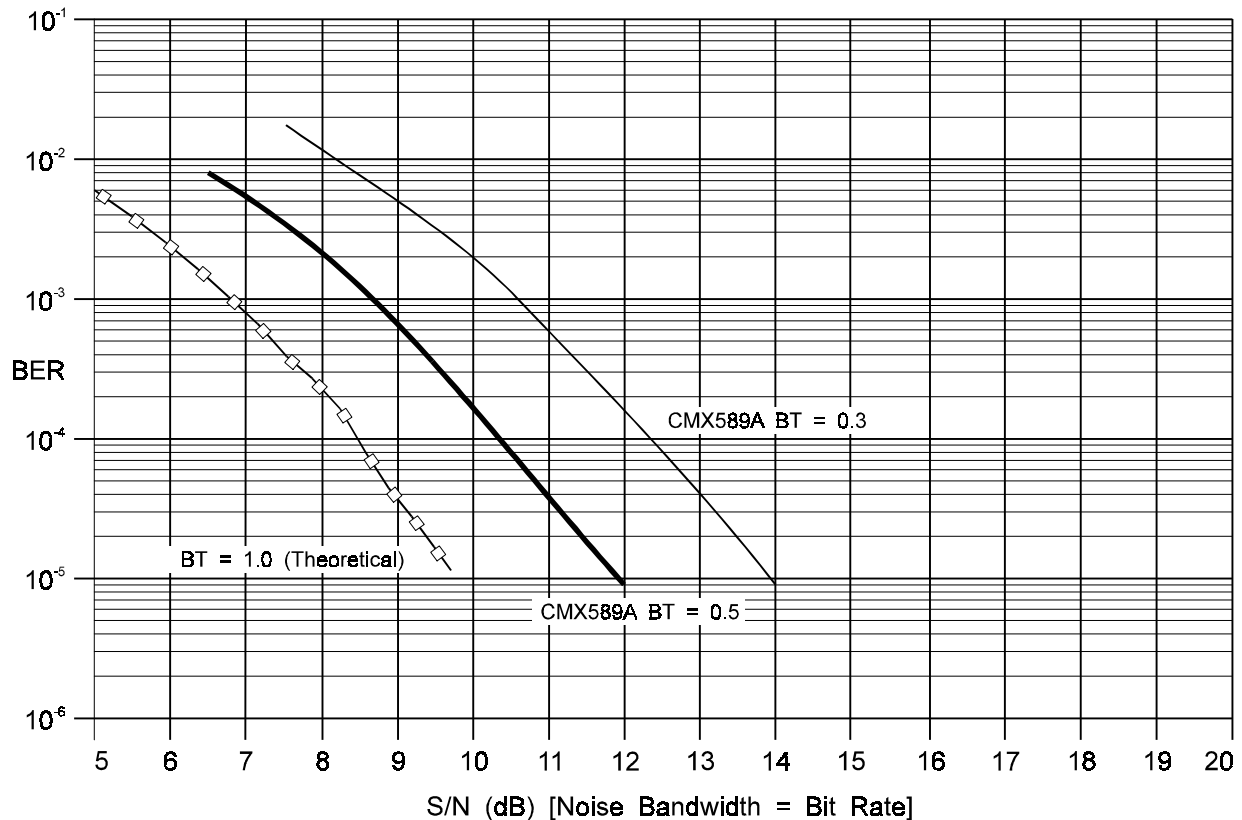

Figure 6: Typical Bit-Error-Rate Performance at $V_{DD} = 5.0V$

Note: Figure 6 indicates typical performance, independent of bit rate (although the applied noise bandwidth is considered to match the bit rate used), radio performance (e.g. IF filter distortion), supply voltage (higher bit rates require $V_{DD} \geq 4.5V$), and other 'real world' factors.

4.2.6 Rx Signal Quality

The effect of input Rx Signal quality on the Rx S/N output is shown in Figure 7.

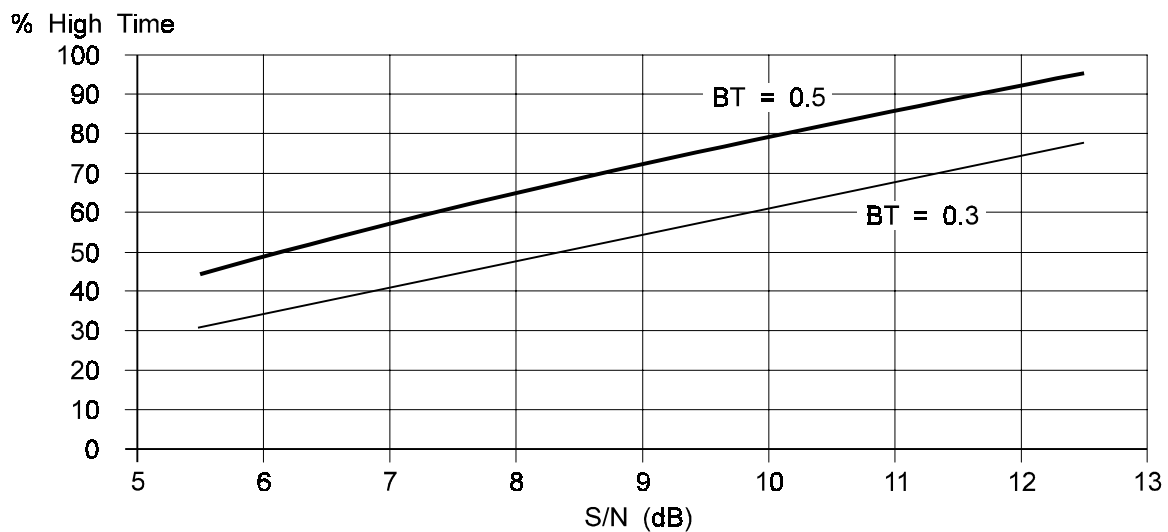

Figure 7: Typical Rx S/N Output High Time (%) vs. Input S/N

4.3 Transmit

4.3.1 Tx Signal Path Description

The binary data applied to the Tx Data input is retimed within the chip on each rising edge of the Tx Clock and then converted to a 1-volt peak-to-peak binary signal centred at V_{BIAS} (for $V_{DD}=5.0V$)

If the Tx Enable input is high, then this internal binary signal will be connected to the input of the Lowpass Tx Filter, and the output of the filter connected to the Tx Out pin.

Tx Enable	Tx Filter Input	Tx Out Pin
1	Data @ $\frac{V_{DD}}{5} V_{P-P}$ e.g. 1V _{P-P} for $V_{DD}=5V$	Filtered 'Tx Filter Input'
0	V_{BIAS}	V_{BIAS} via 500k Ω

A 'low' input to the Tx Enable will connect the input of the Tx Filter to V_{BIAS} , and disconnect the Tx Out pin from the filter, connecting it instead to V_{BIAS} through a high resistance (nominally 500k Ω).

The Tx Filter has a lowpass frequency response, which is approximately gaussian in shape as shown in Figure 9, to minimize amplitude and phase distortion of the binary signal while providing sufficient attenuation of the high frequency-components which would otherwise cause interference into adjacent radio channels. The actual filter bandwidth to be used in any particular application will be determined by the overall system requirements. The attenuation-vs.-frequency response of the transmit filtering provided by the CMX589A has been designed to meet the specifications for most GMSK modem systems that are -3dB bandwidth switchable between 0.3 and 0.5 times the data bit-rate (BT).

Note: An external RC network is required between the Tx Out pin and the input to the Frequency Modulator (see Figure 2 and Figure 3). This network, which can form part of any DC level shifting and gain adjustment circuitry, forms an important part of the transmit signal filtering. The ground connection to capacitor C1 should be positioned to give maximum attenuation of high-frequency noise into the modulator.

The signal at Tx Out is centered around V_{BIAS} , going positive for logic '1' (high) level inputs to the Tx Data input and negative for logic '0' (low) inputs.

When the transmit circuits are put into a powersave mode (by a logic '1' to the Tx PS pin) the output voltage of the Tx Filter will go to high impedance. When power is subsequently restored to the Tx filter, its output will take several bit-times to settle. The Tx Enable input can be used to prevent these abnormal voltages from appearing at the Tx Out pin.

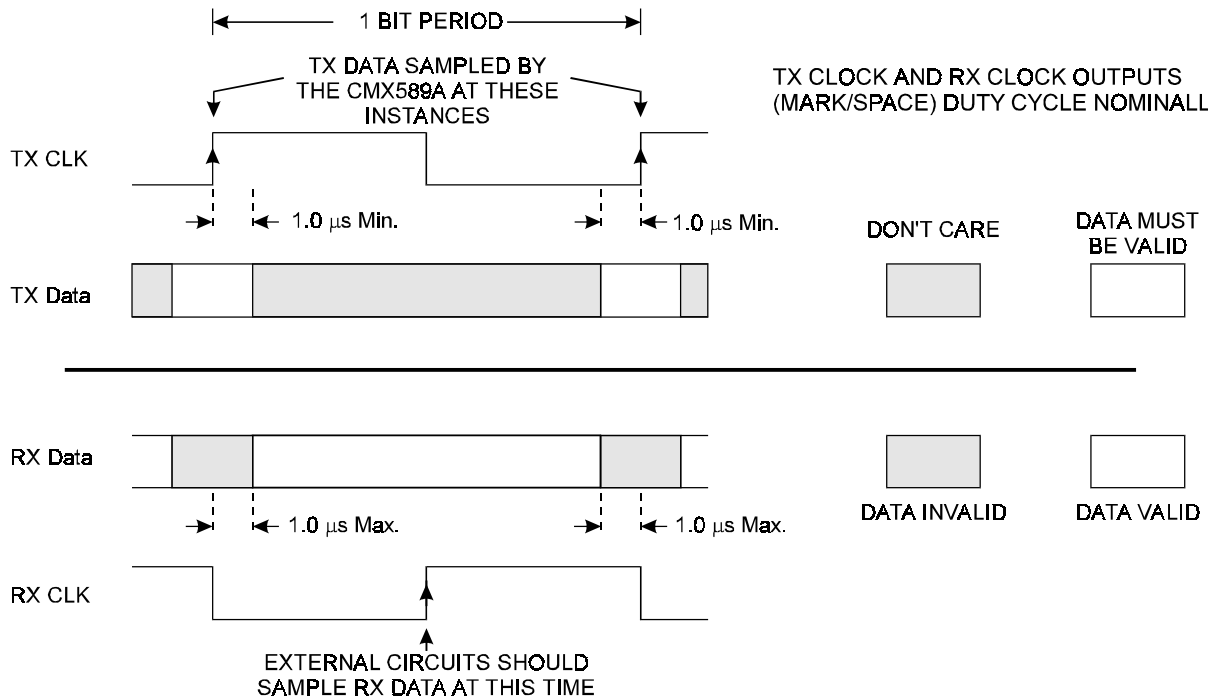

Figure 8: Rx and Tx Clock Data Timings

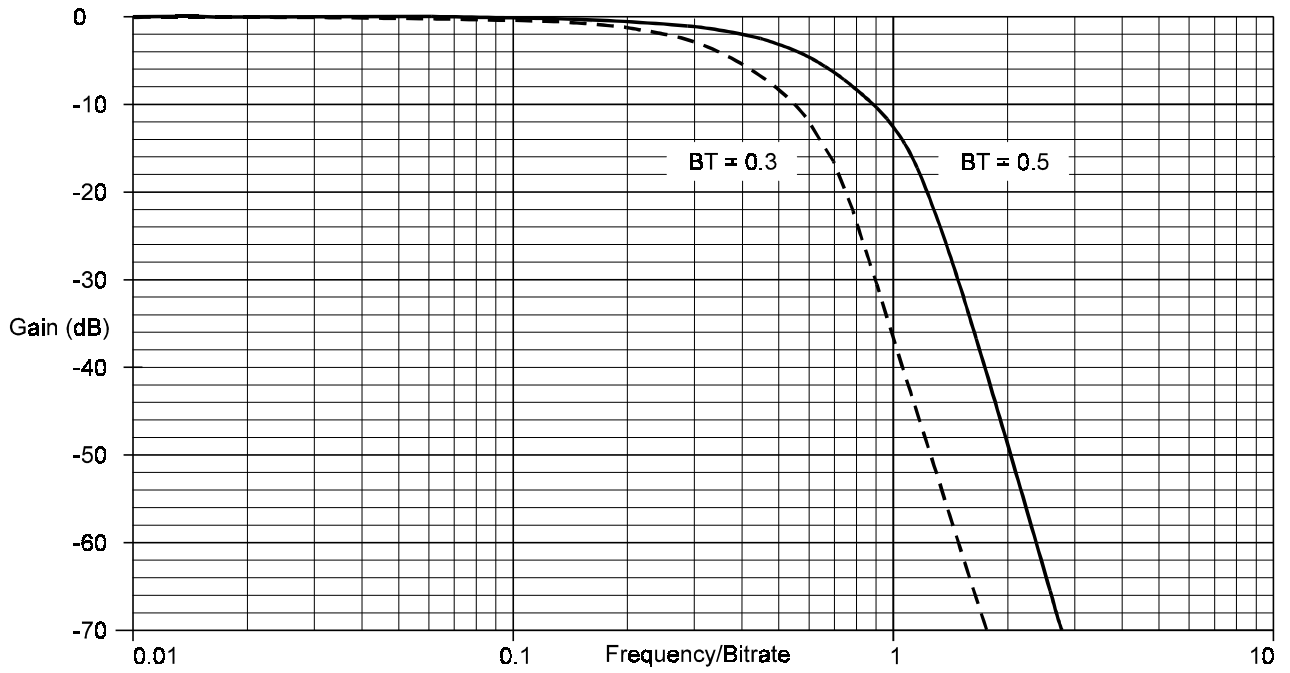

Figure 9: Tx Filter Response

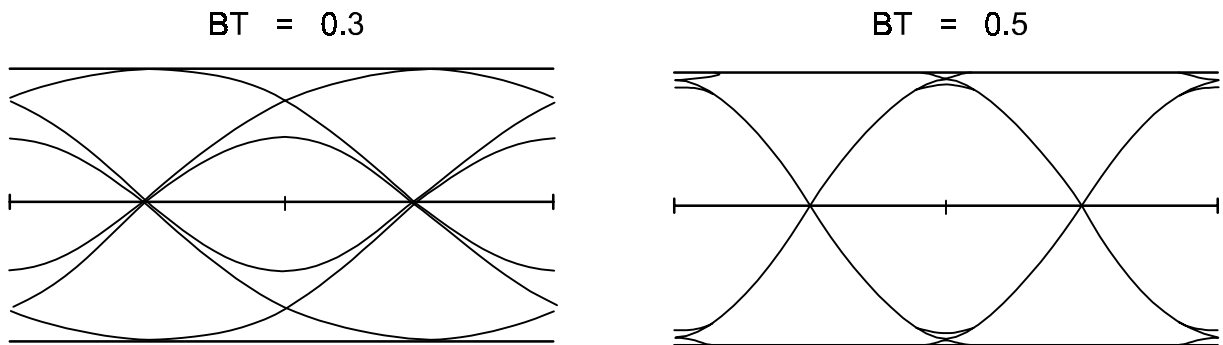

Figure 10: Typical Transmit Eye Patterns

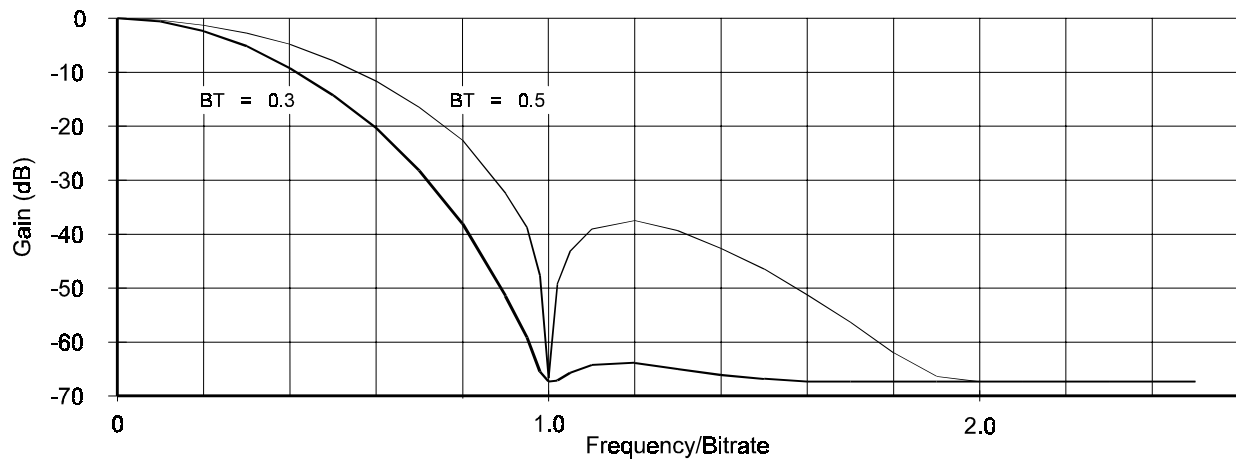

Figure 11: Tx Output Spectrum (Random Data)

4.4 Data Formats

The receive section of the CMX589A works best with data which has a reasonably random structure --the data should contain approximately the same number of 'ones' as 'zeroes' with no long sequences (>100 bits) of consecutive ones or zeroes. Also, long sequences (>100 bits) of 10101010 ... patterns should be avoided.

For this reason, it is recommended that data be made random in some manner before transmission, for example by exclusive-ORing it with the output of a binary pseudo-random pattern generator.

Where data is transmitted in bursts, each burst should be preceded by a preamble designed to allow the receive modem to establish timing and level lock as quickly as possible. This preamble for BT=0.3 should be at least 16 bits long, and should preferably consist of alternating pairs of ones and zeros i.e. 110011001100....; the eye of pattern 10101010 has the most gradual slope and will yield poor peak levels for the Rx circuits. For BT=0.5 the eye pattern of 10101010... has reduced intersymbol interference and may be used as the preamble (DC Acq pin should be held high during preamble). See Figure 5.

4.5 Acquisition and Hold Modes

The RXDCacq and PLLacq inputs must be pulsed High for about 16 bits at the start of reception to ensure that the DC measurement and timing extraction circuits lock-on to the received signal correctly. Once lock has been achieved, the above inputs should be taken Low again.

In most applications, there will be a DC step in the output voltage from the receiver FM discriminator due to carrier frequency offsets as channels are changed or when the remote transmitter is turned on.

The CMX589A can tolerate DC offsets in the received signal of at least $\pm 10\%$ of V_{DD} with respect to V_{BIAS} , (measured at the Rx Feedback pin). However, to ensure that the DC offset compensation circuit operates correctly and with minimum delay, the Low to High transition of the RXDCacq and PLLacq inputs should occur after the mean input voltage to the CMX589A has settled to within about 0.1V of its final value.

Note: This can place restrictions on the value of any series signal coupling capacitor.

As well as using the Rx Hold input to freeze the Level Measuring and Clock Extraction circuits during a signal fade, it may also be used in systems which use a continuously transmitting control channel to freeze the Rx circuitry during transmission of a data packet, allowing reception to resume afterwards without losing bit synchronization. To achieve this, the CMX589A Xtal clock needs to be accurate enough that the derived RxClock output does not drift by more than about 0.1 bit time from the actual received data-rate during the time that the RxHold input is 'Low'.

However; the RXDCacq input may need to be pulsed High for 2 bit durations to re-establish the level measurements if the RxHold input is Low for more that a few hundred bit-times (exact number depends on system crystal tolerances).

The voltages on the Doc1 and Doc2 pins reflect the average peak positive and negative excursions of the (filtered) receive signal, and could therefore be used to derive a measure of the data signal amplitude.

Note: These pins are driven from very high-impedance circuits, so that the DC load presented by any external circuitry should exceed $10M\Omega$ to V_{BIAS} .

5 Application

5.1 Radio Channel Requirements

To achieve legal adjacent channel performance at high bit-rates, a radio with an accurate carrier frequency and an accurate modulation index is required. For optimum channel utilization, (e.g. low BER and high data-rates) attention must be paid to the phase and frequency response of both the IF and baseband circuitry.

5.1.1 Bit Rate, BT, and Bandwidth

The maximum data rate that can be transmitted over a radio channel depends on the following:

- Channel spacing
- Allowable adjacent channel interference
- Tx filter bandwidth
- Peak carrier deviation (Modulation Index)
- Tx and Rx carrier frequency accuracies
- Modulator and Demodulator linearity
- Rx IF filter frequency and phase characteristics
- Use of error correction techniques
- Acceptable error-rate

As a guide to MOBITEK operation, a raw data-rate of 8kbps at 12.5kHz channel spacing may be achievable - depending on local regulatory requirements- using a ± 2 kHz maximum deviation, a BT of 0.3, and no more than 1.5kHz discrepancy between Tx and Rx carrier frequencies. Forward error correction (FEC) could then be used with interleaving to reduce the effect of burst errors.

Reducing the data-rate to 4.8kbps would allow the BT to be increased to 0.5, improving the error-rate performance.

5.1.2 FM Modulator, Demodulator and IF

For optimum performance, the eye pattern of the received signal (when receiving random data) applied to the CMX589A should be as close as possible to the Transmit eye pattern examples shown in Figure 10.

Of particular importance are general symmetry, cleanliness of the zero-crossings, and for a BT of 0.3, the relative amplitude of the inner eye opening.

To achieve this, attention must be paid to:

- Linearity and frequency/phase response of the Tx frequency modulator. Unless the transmit data is especially encoded to remove low frequency components, the modulator frequency response should extend down to a few hertz. This is because two-point modulation is necessary for synthesized radios.
- Bandwidth and phase response of the Rx IF filters.
- Accuracy of the Tx and Rx carrier frequencies -any difference will shift the received signal towards one of the skirts of the IF filter response.

Ideally, the Rx demodulator should be DC coupled to the CMX589A Rx Signal In pin (with a DC bias added to center the signal at the Rx Feedback pin at $V_{DD}/2$ [V_{BIAS}]). However, AC coupling can be used provided that:

The 3dB cut-off frequency is 20Hz or below (i.e. a 0.1 μ F capacitor in series with 100k Ω).

The data does not contain long sequences of consecutive ones or zeroes.

Sufficient time is allowed after a step change at the discriminator output (resulting from channel changing or the appearance of a RF carrier) for the voltage into the CMX589A to settle before the RXDCacq line is strobed.

5.1.3 Two-Point Modulation

When designing the CMX589A into a radio that uses a frequency synthesizer, a two-point modulation technique is recommended. This is both to prevent the radio's PLL circuitry from counteracting the modulation process, and to provide a clean flat modulation response down to DC.

Figure 12 shows a suggested basic configuration to provide a two-point modulation drive from the CMX589A Tx Output using MX-COM's MX019 Digitally Controlled Quad Amplifier Array. The MX019 elements provide individual set-up, calibration and dynamic control of modulation levels. Level setting control of the amplifiers/attenuators of the MX019 is via an 8-bit data word. Note that the MX019 frequency response only supports data rates as high as 8kbps.

With reference to Figure 12:

The buffer amplifier is required to prevent loading of the CMX589A external RC circuit.

Stage B, with R1/R2, provides suitable signal and DC levels for the VCO varactor; C1 is RF decoupling. The drive level should be adjusted (digitally) to provide the desired deviation.

Stage C, with R3/R4, provides the Reference Oscillator drive (application dependent). This parameter is set by adjusting for minimum AC signal on the PLL control voltage with a low-frequency modulating signal (inside the PLL bandwidth) applied.

Stage D could be used with the components shown if a negative reference drive is required.

Stage A provides buffering and overall level control.

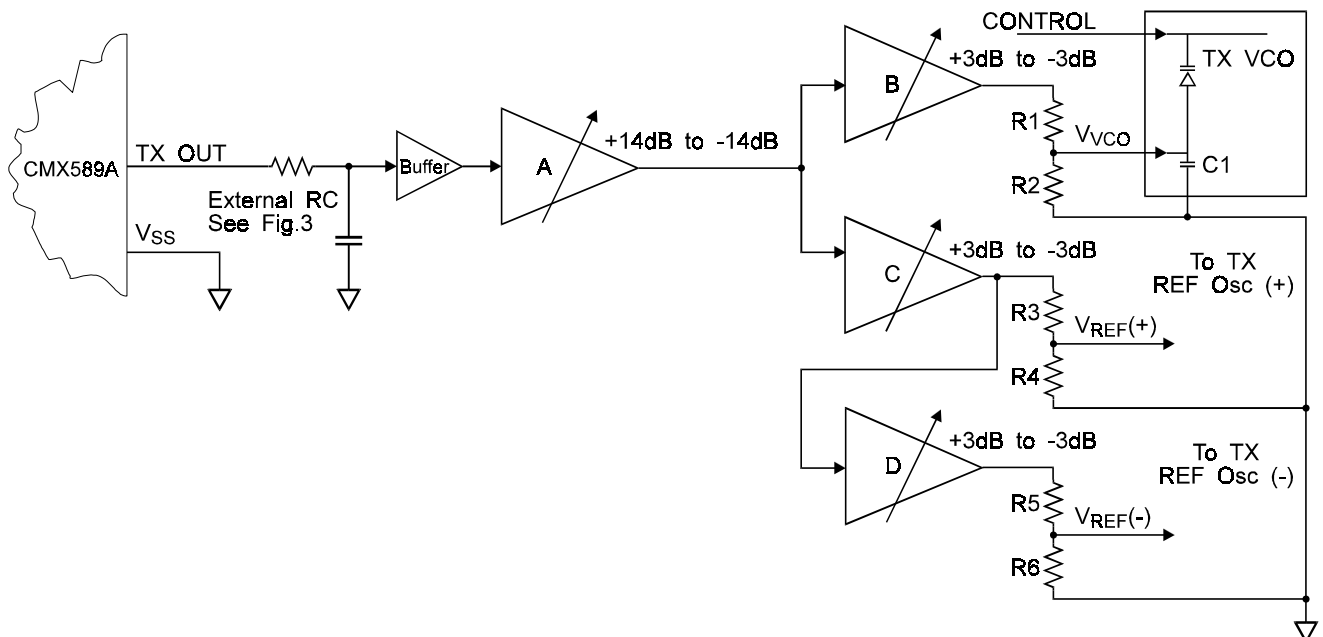

Figure 12: An Example of Two-Point Modulation Drive with Individual Adjustment Using the FX019

5.2 AC Coupling of Tx and Rx Signals

In practical applications, it is possible to arrange AC coupling between the CMX589A Tx Output and the frequency modulator to cut-off at a very low frequency, such as 5.0Hz. AC coupling between the receive discriminator and the input of the CMX589A may need a shorter time-constant to avoid problems from voltage steps at the output of the discriminator when changing channels or when the distant transmitter turns on.

For these reasons, as well as to maintain reasonable BER, the optimum -3dB cut-off frequencies are around 5.0Hz in the Tx path and 20.0Hz in the Rx path.

Figure 13 shows the typical static Bit-Error-Rate performance of the CMX589A operating under nominal conditions for various degrees of AC coupling at the Rx input and the Tx output.

Data Rate = 8kbps $V_{DD} = 5.0V$ $T_{AMB} = 25^{\circ}C$ Tx BT = 0.3

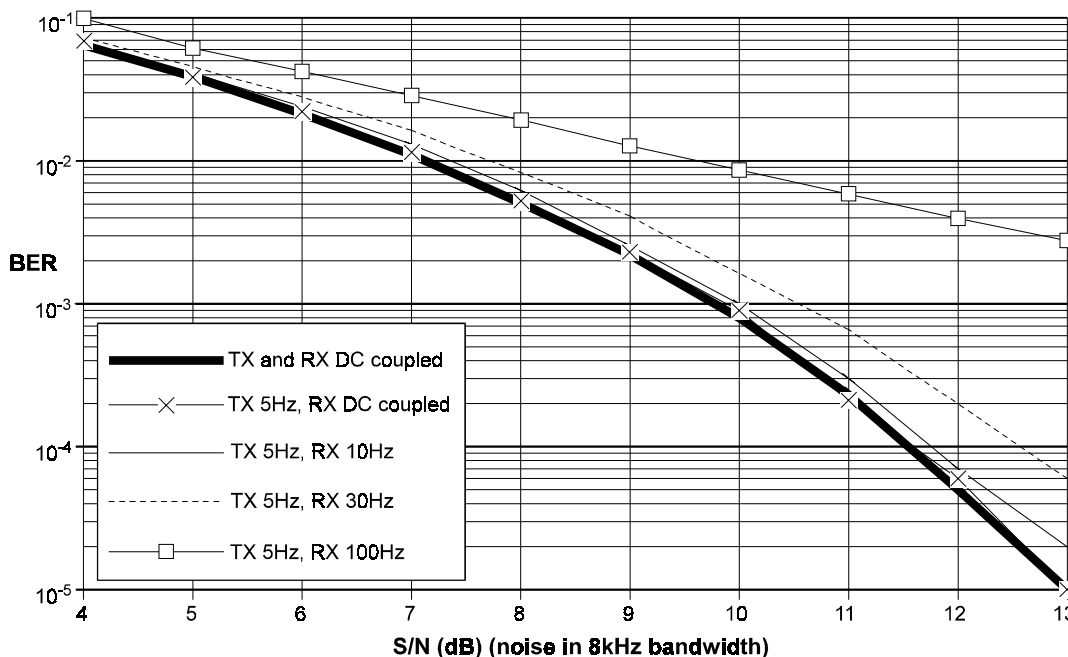

Figure 13: Effect of AC Coupling on Typical Bit-Error Rate

Any AC Coupling at the receive input will transform any step in the voltage at the discriminator output to a slowly decaying pulse which can confuse the modem's level measuring circuits. As illustrated in Figure 14, the time for this step to decay to 37% of its original value is 'RC' where:

$$RC = \frac{1}{2\pi(\text{the 3dB cutoff frequency of the RC network})}$$

which is 32ms, or 256 bit times at 8kbps, for a 5Hz network.

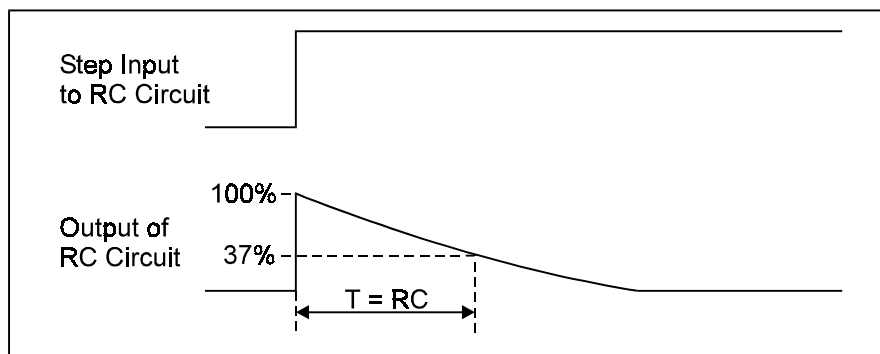

Figure 14: Decay time-AC Coupling

6 Performance Specifications

6.1 Electrical Specifications

6.1.1 Absolute Maximum Limits

Exceeding these maximum ratings can result in damage to the device.

General	Notes	Min.	Typ.	Max.	Units
Supply ($V_{DD}-V_{SS}$)		-0.3		7.0	V
Voltage on any pin to V_{SS}		-0.3		$V_{DD} + 0.3$	V
Current					
V_{DD}		-30		30	mA
V_{SS}		-30		30	mA
Any other pin		-20		20	mA
D2 / P4 Packages					
Total allowable Power dissipation at $T_{AMB} = 25^{\circ}\text{C}$				800	mW
Derating above 25°C			13		mW/ $^{\circ}\text{C}$
Operating Temperature		-40		85	$^{\circ}\text{C}$
Storage Temperature		-55		125	$^{\circ}\text{C}$
D5 Package					
Total allowable Power dissipation at $T_{AMB} = 25^{\circ}\text{C}$				550	mW
Derating above 25°C			9		mW/ $^{\circ}\text{C}$
Operating Temperature		-40		85	$^{\circ}\text{C}$
Storage Temperature		-55		125	$^{\circ}\text{C}$
E2 Package					
Total allowable Power dissipation at $T_{AMB} = 25^{\circ}\text{C}$				320	mW
Derating above 25°C			5.3		mW/ $^{\circ}\text{C}$
Operating Temperature		-40		85	$^{\circ}\text{C}$
Storage Temperature		-55		125	$^{\circ}\text{C}$

Table 7: Absolute Maximum Ratings

6.1.2 Operating Limits

Correct Operation of the device outside these limits is not implied.

	Notes	Min.	Typ.	Max.	Units
Supply ($V_{DD}-V_{SS}$)		3.0	3.3/5.0	5.5	V
Operating Temperature		-40		85	°C
Rx and Tx Data Rate					
$V_{DD} \geq 3.0V$		4		32	kbps
$V_{DD} \geq 4.5V$		4		200	kbps
Xtal Frequency					
$V_{DD} \geq 3.0V$		1.0		5.0	MHz
$V_{DD} \geq 4.5V$		1.0		16.0	MHz
External Clock Frequency					
$V_{DD} \geq 3.0V$	1	1.0		5.0	MHz
$V_{DD} \geq 4.5V$	1	1.0		25.6	MHz
High Pulse Width	1	15			ns
Low Pulse Width	1	15			ns

Table 8: Operating Limits

Operating Limits Notes

1. Timing for an external clock input to the Xtal/Clock pin.

6.1.3 Operating Characteristics

For the following conditions unless otherwise specified.

$V_{DD} = 5.0V$ @ $T_{AMB} = 25^{\circ}C$

Xtal/Clock Frequency = 4.096MHz, Data Rate = 8kbps, Noise Bandwidth = Bit Rate

Static Values			Notes	Min.	Typ.	Max.	Units
Supply Current	Tx PS	Rx PS	1				
I_{DD} ($V_{DD} = 3.0V$)							
	1	1		-	0.5	-	mA
	0	1		-	1.0	-	mA
	1	0		-	1.0	-	mA
	0	0		-	1.5	-	mA
I_{DD} ($V_{DD} = 5.0V$)							
	1	1		-	1.0	-	mA
	0	1		-	2.0	-	mA
	1	0		-	3.0	-	mA
	0	0		-	4.0	-	mA
Input Logic Level							
Logic 1 Input Level				3.5	-	-	V
Logic 0 Input Level				-	-	1.5	V
Logic Input Current			2	-5.0	-	5.0	μA
Output Logic Level							
Logic 1 Output Level ($I_{OH} = 120\mu A$)				4.6	-	-	V
Logic 0 Output Level ($I_{OL} = -120\mu A$)				-	-	0.4	V
Transmit Parameters							
Tx OUT pin DC bias shift caused by change from Tx Enable = 0 to Tx Enable = 1 while Tx PSAVE = 0 at $25^{\circ}C$				-85.0	-	85.0	mV
Tx OUT, Output Impedance			3	-	1.0	-	k Ω
Tx Out, Level			4, 10	0.8	1.0	1.2	V _{P-P}
Output DC Offset			12	-0.125	-	0.125	V
Tx Data Delay							
BT = 0.3			5	-	2.0	2.5	bit-periods
BT = 0.5			5	-	1.5	2.0	bit-periods
Tx PS to Output-Stable time			6	-	4.0	-	bit-periods
Receive Parameters							
Rx Amplifier							
Input Impedance				1.0	-	-	M Ω
Output Impedance			7	-	10.0	-	K Ω
Voltage Gain				-	50.0	-	dB
Rx Filter Signal Input Level			8, 10	0.7	1.0	1.3	V _{P-P}
Rx Time Delay			9	-	-	3.0	bit-

Static Values	Notes	Min.	Typ.	Max.	Units
periods					
On-Chip Xtal Oscillator					
R_{IN}		10.0	-	-	M Ω
R_{OUT}	11	-	50.0	-	k Ω
Voltage Gain	11	-	25.0	-	dB

Table 9: Operating Characteristics

Operating Characteristics Notes:

1. Not including current drawn from the CMX589A pins by external circuitry. See Absolute Maximum Ratings.
2. For V_{IN} in the range V_{SS} to V_{DD} .
3. For a load of 10K Ω or greater. Tx PS input at logic '0'; Tx Enable = '1'.
4. Data pattern of 1111000011110000...
5. Measured between the rising edge of Tx Clock and the centre of the corresponding bit at Tx Out.
6. Time between the falling edge of the Tx PS and the Tx Out voltage stabilizing to normal output levels.
7. For a load of 10k Ω or greater. Rx PS input at logic '0'.
8. For optimum performance, Measured at the Rx Feedback pin for an 1111000011110000... pattern.
9. Measured between the center of bit at Rx Signal In and corresponding rising edge of the Rx Clock.
10. Levels are proportional to applied V_{DD}
11. Small signal measurement at 1.0kHz with no load on Xtal output.
12. (Tx OUT enabled DC level) – (Tx Out disabled DC level) when transmitting a repeating 11110000 bit pattern.

6.2 Packages

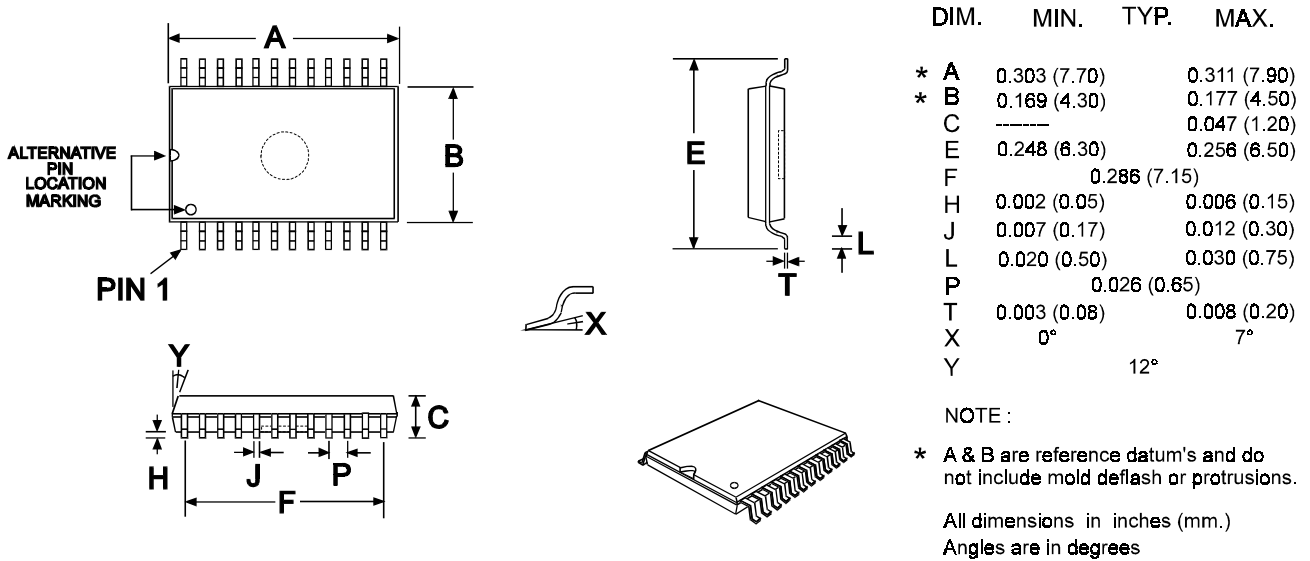

Figure 15: 24-pin TSSOP Mechanical Outline: Order as part no. CMX589AE2

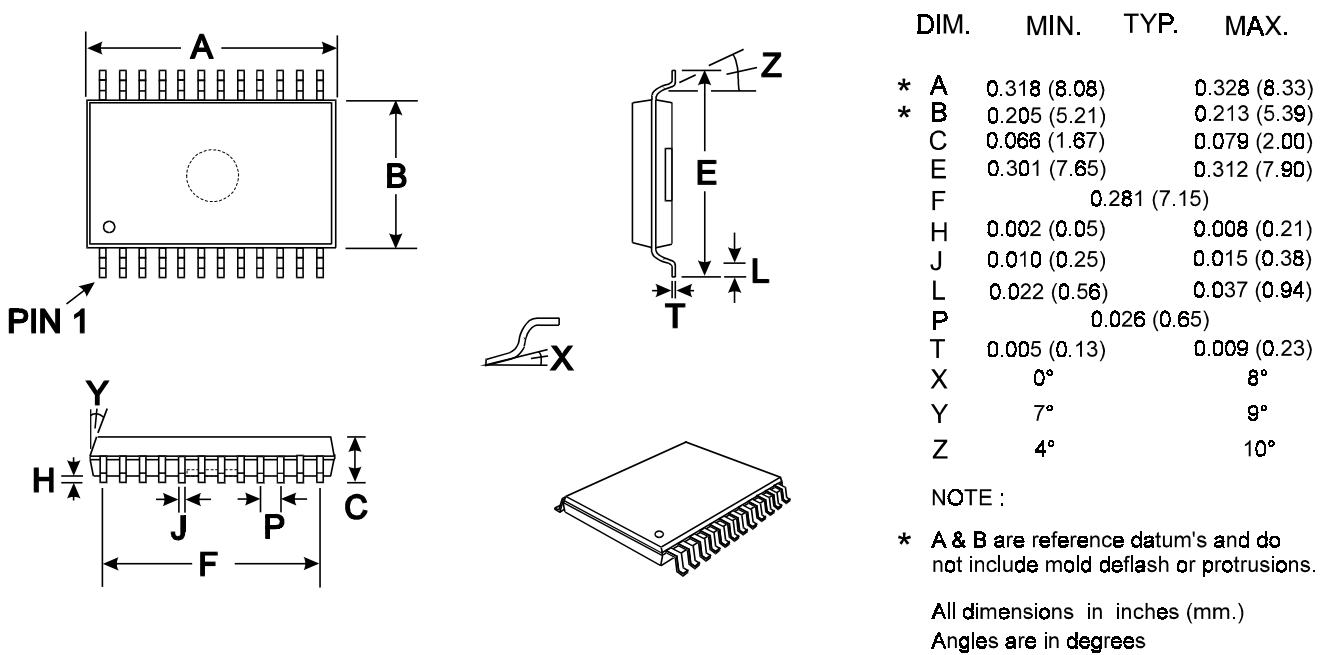
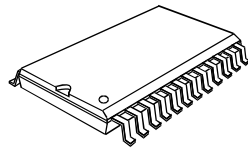
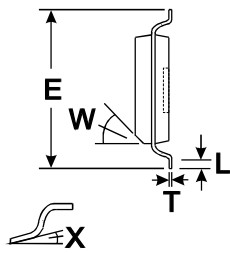
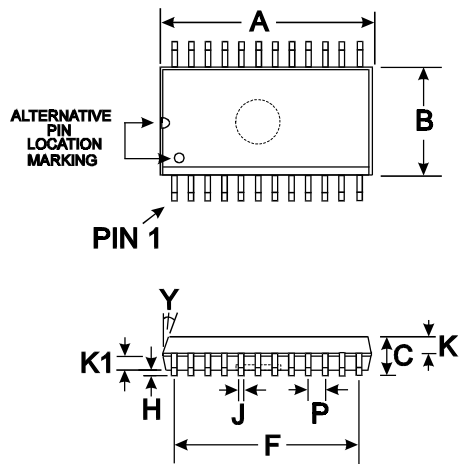

Figure 16: 24-pin SSOP Mechanical Outline: Order as part no. CMX589AD5



DIM. MIN. TYP. MAX.

* A	0.597 (15.16)	0.613 (15.57)	
* B	0.286 (7.26)	0.299 (7.59)	
C	0.093 (2.36)	0.105 (2.67)	
E	0.390 (9.90)	0.419 (10.64)	
F		0.550 (14.1)	
H	0.003 (0.08)	0.020 (0.51)	
J	0.013 (0.33)	0.020 (0.51)	
K		0.041 (1.04)	
K1		0.041 (1.04)	
L	0.016 (0.41)	0.050 (1.27)	
P		0.050 (1.27)	
T	0.009 (0.23)	0.0125 (0.32)	
W		45°	
X	0°		10°
Y		7°	

NOTE :

* A & B are reference datum's and do not include mold deflash or protrusions.

All dimensions in inches (mm.)
Angles are in degrees

Figure 17: 24-pin SOIC Mechanical Outline: Order as part no. CMX589AD2

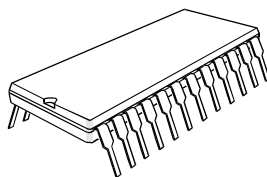
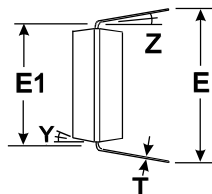
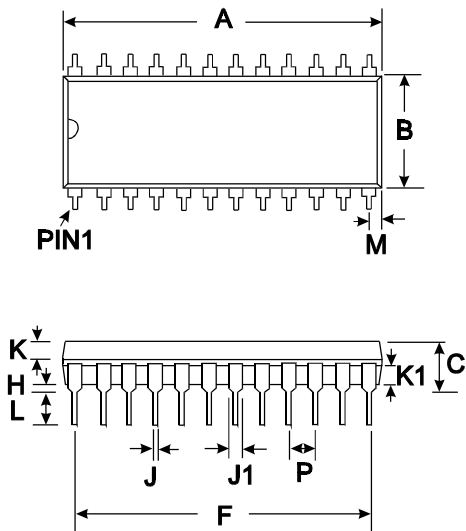

DIM. MIN. TYP. MAX.

* A	1.200 (30.48)	1.270 (32.26)	
* B	0.500 (12.70)	0.555 (14.10)	
C	0.151 (3.84)	0.220 (5.59)	
E	0.600 (15.24)	0.670 (17.02)	
E1	0.590 (14.99)	0.625 (15.88)	
F		1.10 (27.94)	
H	0.015 (0.38)	0.045 (1.14)	
J	0.015 (0.38)	0.023 (0.58)	
J1	0.040 (1.02)	0.065 (1.65)	
K	0.066 (1.68)	0.074 (1.88)	
K1	0.060 (1.52)	0.074 (1.88)	
L	0.121 (3.07)	0.160 (4.06)	
M		0.180 (4.58)	
P		0.100 (2.54)	
T	0.008 (0.20)	0.015 (0.38)	
Y		7°	
Z		4°	

NOTE :

* A & B are reference datum's and do not include mold deflash or protrusions.

All dimensions in inches (mm.)
Angles are in degrees

Figure 18: 24-pin PDIP Mechanical Outline: Order as part no. CMX589AP4

Handling precautions: This product includes input protection, however, precautions should be taken to prevent device damage from electro-static discharge. CML does not assume any responsibility for the use of any circuitry described. No IPR or circuit patent licences are implied. CML reserves the right at any time without notice to change the said circuitry and this product specification. CML has a policy of testing every product shipped using calibrated test equipment to ensure compliance with this product specification. Specific testing of all circuit parameters is not necessarily performed.