

Data Sheet
NVE AFLxxx-xx
Low Power Low Voltage Digital Switch

- Low Voltage Operation Down to 0.9V
- Low Current Consumption
- Digital Switch Output
- Precise Detection of Low Magnetic Field
- Ultra – Small MSOP8 and TDFN6 Packages
- Available in Die Form for Ultra-Miniature Applications
- Cannot Be Damaged By Large Magnetic Fields

Description – NVE’s AFL series devices are digital switch products designed to run at very low voltages and very low currents. Operation with single battery supplies is possible with these parts. The output is configured for use as a “switch” to detect a magnetic field level. The chip’s output turns on at the specified magnetic field, and turns off when the magnetic field is removed. Two output types are available, a current sinking output or a current sourcing output. Both outputs are capable of supplying up to 100 μ A of current. An external pull-up or pull-down resistor is required for the output. The IC is available in NVE’s MSOP8 package, TDFN6 package, or in die form.

The AFL series product part numbers follow the general form given below. As shown below, the first “x” in the part number specifies the voltage range of operation of the part, the second “x” specifies the output configuration, the third “x” specifies the magnetic operate point, and the last pair specify the package type. The following sections define these variations in detail.

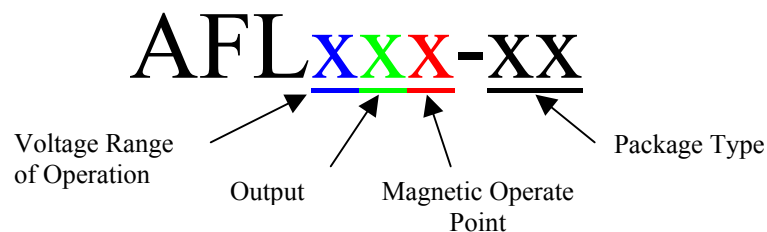

Voltage Range of Operation

The first numeric digit of the part number NVE AFLxxx-xx specifies the operating voltage range of the part. Four ranges are available, as shown in the table below:

AFLxxx-xx

Number	Voltage Range of Operation
0	0.9V to 1.3V
1	1.8V to 2.5V
2	2.7V to 3.6V
3	4.5V to 5.5V

Inside these operating ranges, the quiescent current required by the parts will meet the stated specifications. Any of the parts may be operated at higher voltage levels than shown in this table, up to a maximum of 7V. However, if operated above the listed voltage range, quiescent current required by the part will increase. For example, the “1” part could be operated up to 3.0V, but additional current would be required.

Custom parts for different voltage ranges of operation can be acquired from NVE. Minimum order quantities, special pricing, NRE charges, and lead times may apply. Please contact NVE with your requirements.

Output

The second numeric digit of the part number specifies the output configuration of the part. Four different output configurations are available, as shown in the following table:

AFLxxxx-xx

Number	Output Type
0	Normally Off, Current Sink
1	Normally On, Current Sink
2	Normally On Current Source
3	Normally Off Current Source

“Normally Off” means that with no magnetic field applied, the output will not provide current; when the magnetic field is applied, the output current will turn on. “Normally On” is the opposite. The parts will sink or source up to 100 μ A of current; the output current is not included in the quiescent current specification.

Magnetic Operate Point and Direction of Sensitivity

All AFL series parts feature the cross axis direction of sensitivity, as shown on the package diagram. Any of NVE's standard magnetic operate points are available, as shown in the table below. Non-standard magnetic operate points are available, but special pricing, minimum order quantities, NRE charges, and lead times may apply.

AFLxxx-xx

Number	Magnetic Operate Point
0	10 Oe
1	20 Oe
2	28 Oe
3	40 Oe
4	80 Oe

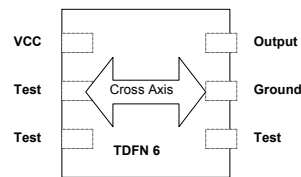
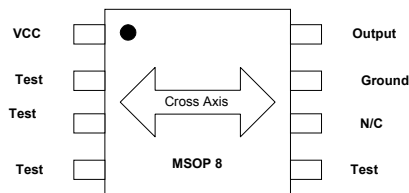

Package Type

The AFL series parts are available in two different packages: an MSOP 8 pin small outline package, and a TDFN 6 pin ultra-miniature package. The parts are also available in die form. Package drawings are shown at the end of this specification.

The following table defines the last two digits in the AFL part number:

AFLxxx-xx

Number	Package Type
00	MSOP8
01	IC Only
10	TDFN6

The following parts in this series are currently available as production items:

AFL000-10E	AFL000-01
AFL020-00E	AFL030-00E
AFL100-00E	AFL100-10E
AFL200-00E	AFL300-00E

Note: The “E” suffix on the part number indicates a lead-free, RoHS compliant packaged part. All die versions (-01 suffix) are lead-free and RoHS compliant. Other variations of the parts will become available as customer requirements dictate.

Electrical and Magnetic Specifications

Parameter	Min	Typ	Max	Units
Magnetic Operate Point (AFLxx0-xx)	7	10	13	Oersteds
Operate/Release Differential (AFLxx0-xx)	2		8	Oersteds
Magnetic Operate Point (AFLxx1-xx)	15	20	25	Oersteds
Operate/Release Differential (AFLxx1-xx)	5		15	Oersteds
Magnetic Operate Point (AFLxx2-xx)	21	28	34	Oersteds
Operate/Release Differential (AFLxx2-xx)	5		15	Oersteds
Operating Voltage (AFL0xx-xx)	0.9	1.1	1.3	Volts
Operating Voltage (AFL1xx-xx)	1.8	2.2	2.5	Volts
Operating Voltage (AFL2xx-xx)	2.7	3.2	3.6	Volts
Operating Voltage (AFL3xx-xx)	4.5	5.0	5.5	Volts
Quiescent Current (AFL000-xx)	20	35	55	μA
Quiescent Current (AFL020-xx)	30	50	75	μA
Quiescent Current (AFL030-xx)	15	35	55	μA
Quiescent Current (AFL100-xx)	25	35	45	μA
Quiescent Current (AFL200-xx)	30	35	45	μA
Quiescent Current (AFL300-xx)	30	40	50	μA
Maximum Output Drive Current (Sink or Source)	100			μA
V _{OL} at 100μA Output Drive Current			0.200	Volts
V _{OH} at 100μA Output Drive Current	VCC-0.150			Volts
Frequency Response	100			KHz
Temperature Range of Operation	-20		85	°C

Notes:

1. **Large Magnetic Fields WILL NOT cause damage to NVE GMR Sensors**
2. 1 Oe (Oersted) = 1 Gauss in air = 0.1 mT

Operation – The end user must apply a magnetic field planar with the IC package, in the direction of sensitivity of the part. When the magnetic field intensity reaches the magnetic operate point of the IC, the digital output will turn on. The end user must also use a pull-up or pull down resistor on the output terminal.

Functional Block Diagram and Pinout:

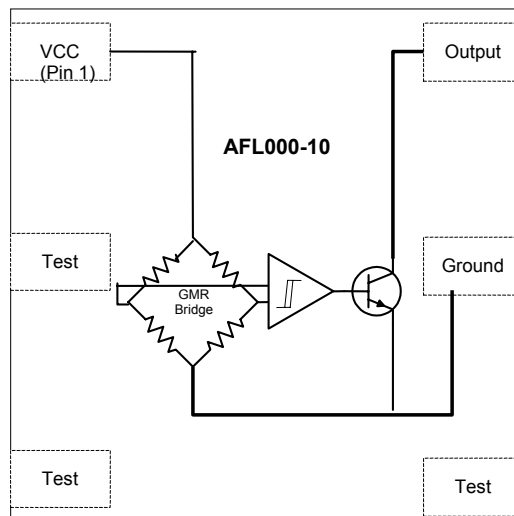
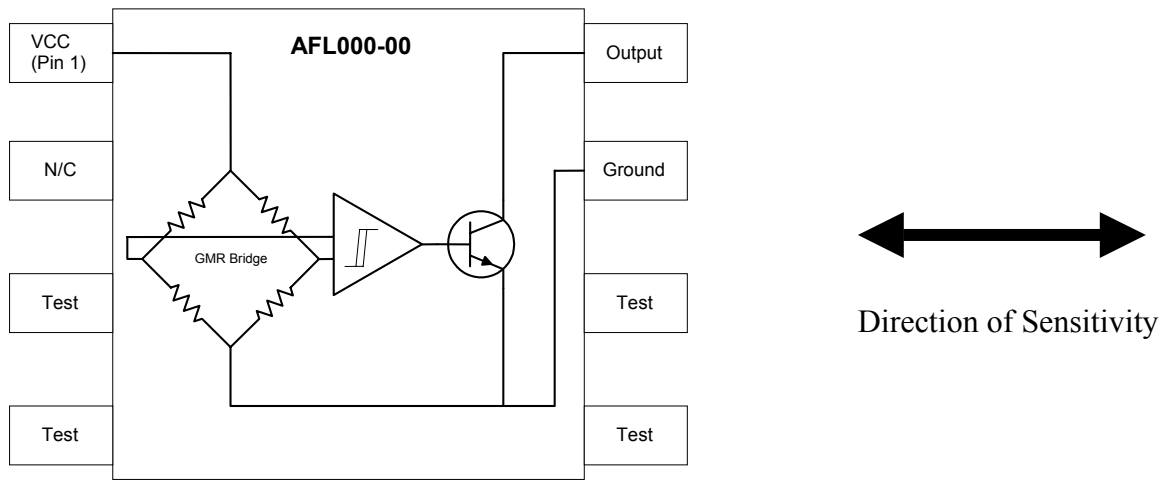

IC Drawing and Layout:

The size of the IC is approximately 1.45mm X 1.5mm. A drawing of the IC is shown below:

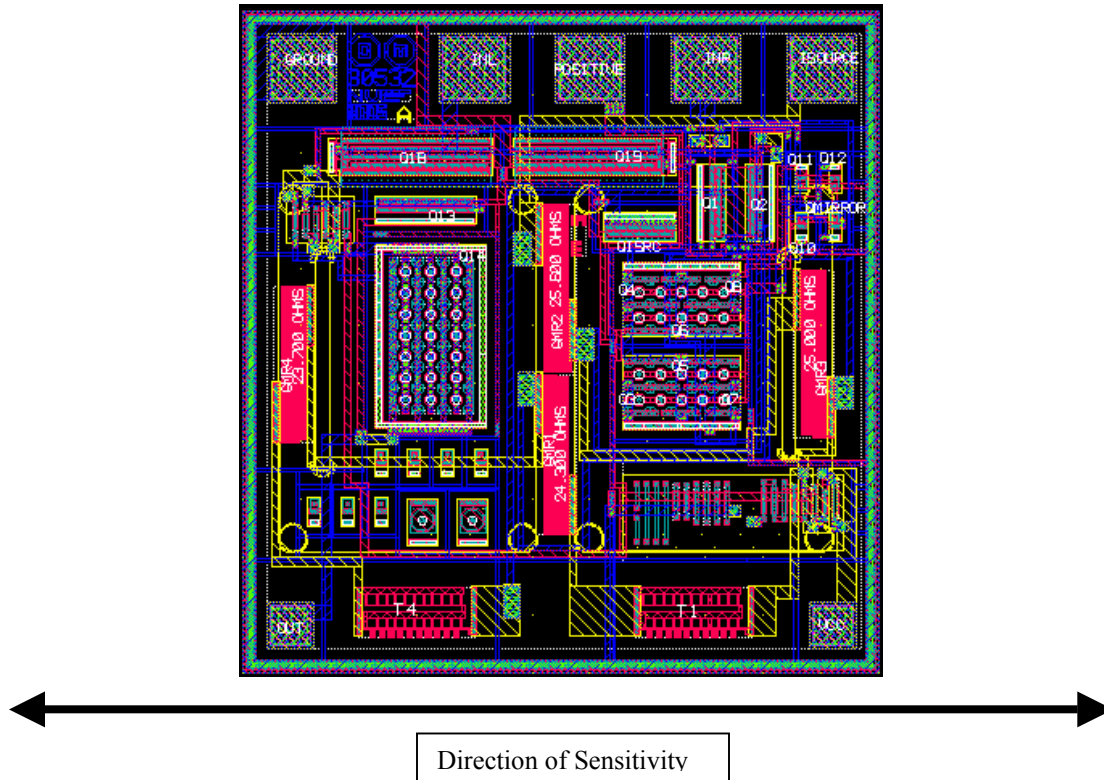

Package Drawing – MSOP8

Note: MSOP8 Package has thermal power dissipation of 320°C/Watt in free air. Attaching the package to a circuit board improves thermal performance.

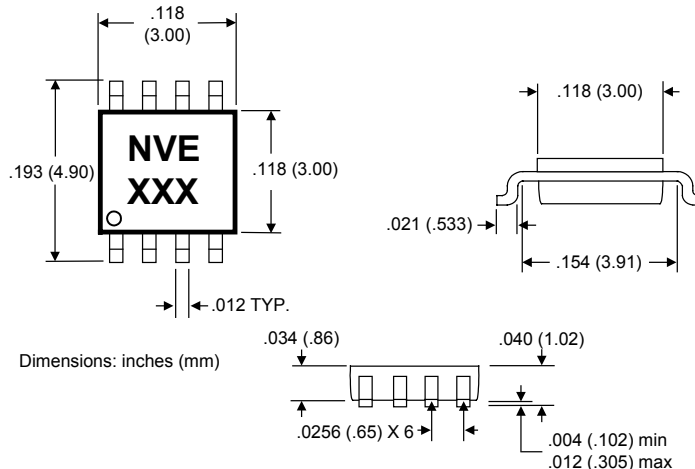

Package Drawing – TDFN6 2.5mm X 2.5mm

Note: Dimensions in mm. TDFN6 package has thermal power dissipation of 320°C/Watt in free air. Attaching the package to a circuit board improves thermal performance.

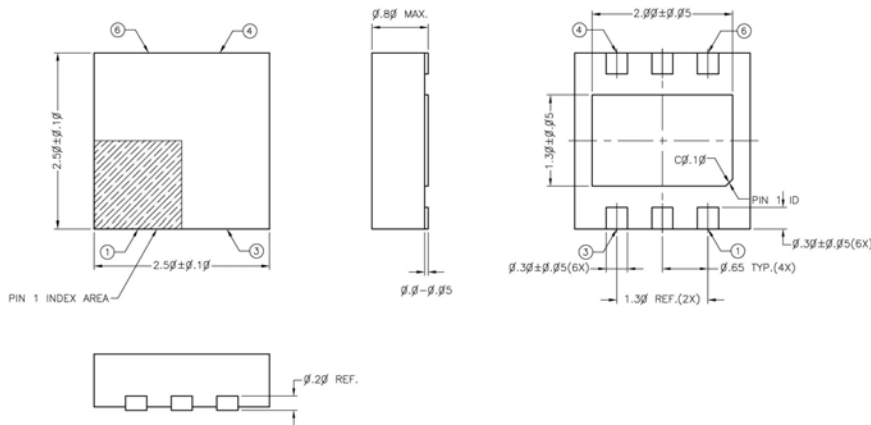

For the TDFN6 and MSOP8 packages, the complete part number will not fit on the package, so a 3 digit code is used. The codes for the indicated part numbers are given below:

Part Number	Marking Code
AFL000-10E	QBBe
AFL020-00E	PBCe
AFL030-00E	PBDe
AFL100-00E	PBFe
AFL100-10E	QBFe
AFL200-00E	PBGe
AFL300-00E	PBHe